



NATIONAL ALUMINIUM
PRODUCTS COMPANY SAOG

N Minimal Catalogue



10 - 2020 - V.02

All rights reserved.

No part of this publication may be reproduced, stored in a retrieval system or transmitted in any form or by any means electronic, mechanical, photocopying, recording or otherwise, without prior permission of NAPCO.





Index

Company Profile	06
Technical Information	07
N Minimal Series	08



About Us

National Aluminium Products Company SAOG (NAPCO) was established in 1984 and is one of the leading extruders of aluminium profiles in the GCC market. Located in the Sultanate of Oman, the manufacturing plant is spread over 65,000 sq meters in the Rusayl Industrial estate.

NAPCO offers a wide range of Aluminium profile extrusions in finishes that suit functional modern design specifications. The company has left its mark on the architectural landscape of the Middle East with its renowned quality products being used in a number of prominent structures.

Our annual production capacity is 42,000 MT with four (4) state of the art presses. The extrusion presses are complemented by one anodizing line and two powder coating lines (vertical & horizontal). NAPCO also houses two wood finish lines and a crimping and bending facility.

NAPCO's commitment to quality has made it the first extrusion company in the Gulf to receive ISO certifications. We are also the only public limited aluminium extrusion company in the entire GCC.

With a consistent focus on innovative production skills and high service standards, we will continue our objective to meet customer demands and expectations.

Technical Information on Aluminium extrusions supplied by NAPCO

A. Equipment & Capacity

Extrusion Press: 4

2000 MT (8') SMS Germany

2800 MT (9') Danieli Breda, Italy

1800 MT (7') Tecalex, Spain

1800 MT (7') Tecalex, Spain

Powder Coating Plant: 2

Horizontal Type, Ercon, UK

Vertical Type, Trasmetal, Italy

Anodizing Line: 1

SAS, Germany

Wood Finish: 2 NATURALL, Italy.

Crimping & Bending Facility.

- **Current Capacity Per Annum**

Extrusion: 42,000

Powder Coating: 27,000

Anodizing: 2,400

Wood Finish: 1,500

B. General Specification

Max profile size CCD 305mm

(*indicative size)

C. Product Range

NAPCO offers a range of over 6000 profiles to suit the architectural and manufacturing industry. NAPCO also develops exclusive dies for customers against their own designs.

- **Aluminium extrusions in:**

Mill Finish

Anodized

Powder Coated and Natural Wood Finish

- **Façade Systems:**

NAPCO is in partnership with world renowned façade system houses in the GCC. Please contact us to discuss your best-fit solution.

D. Anodizing

NAPCO has one anodizing line employing sulphuric acid anodizing process offering a wide range of colour shades such as Silver, Bronze and Black with scope of development of other shades to suit customer requirements.

Specifications: DC Sulphuric Acid Anodizin

As per EN 1 - 12373 and BS 1991 3987

Qualanod Approved

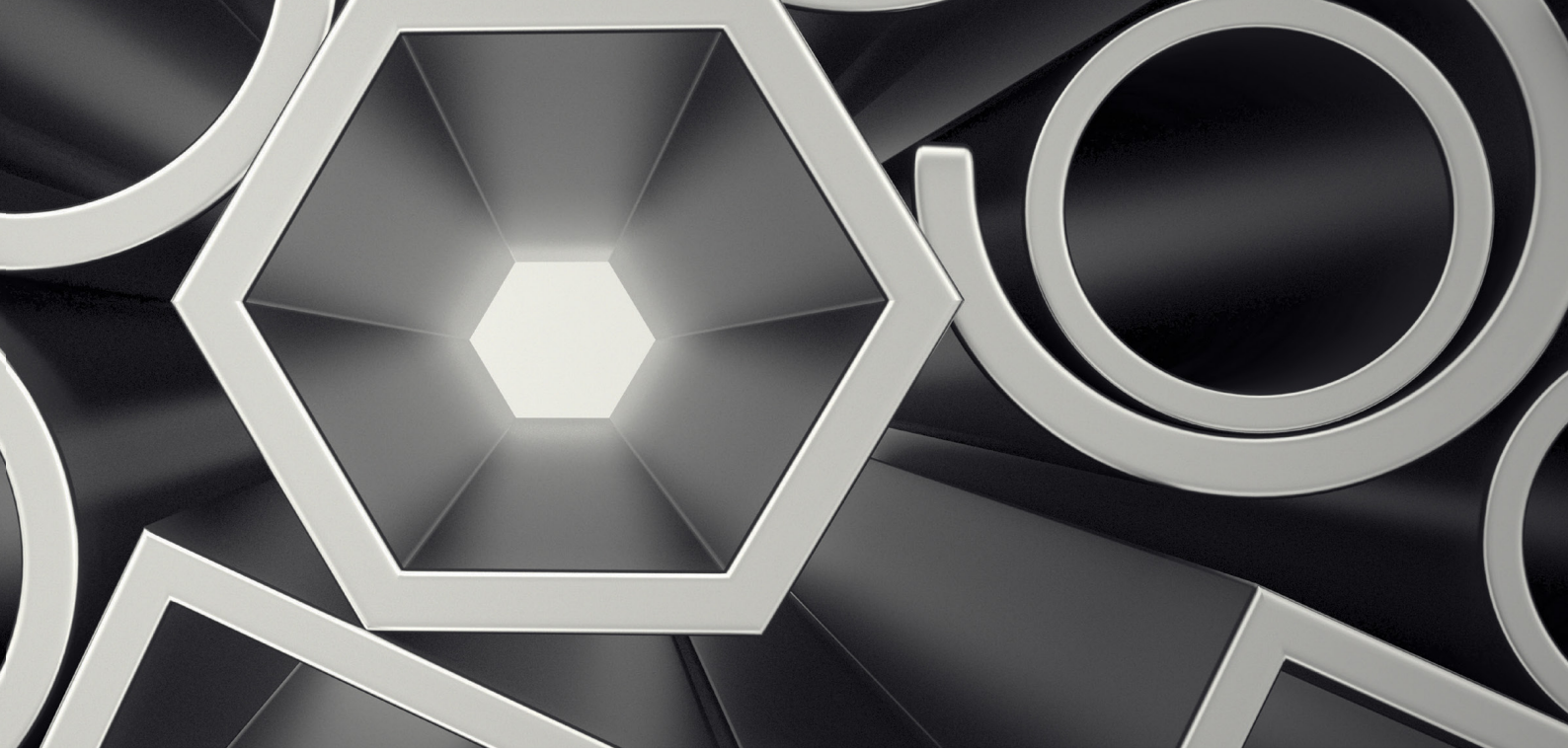

E: Powder Coating

NAPCO has two powder coating lines (horizontal & Vertical) with IR curing ovens. The colour coat thickness in exposed areas is Around 80-60 microns. The new vertical line is able to accommodate profile lengths up to 8 meters.

Qualicoat Approved.

Natural finish is available in seven combinations of Wood patterns.

Specification: As per 6496

F. Certifications



N MINIMAL SERIES



N MINIMAL SERIES

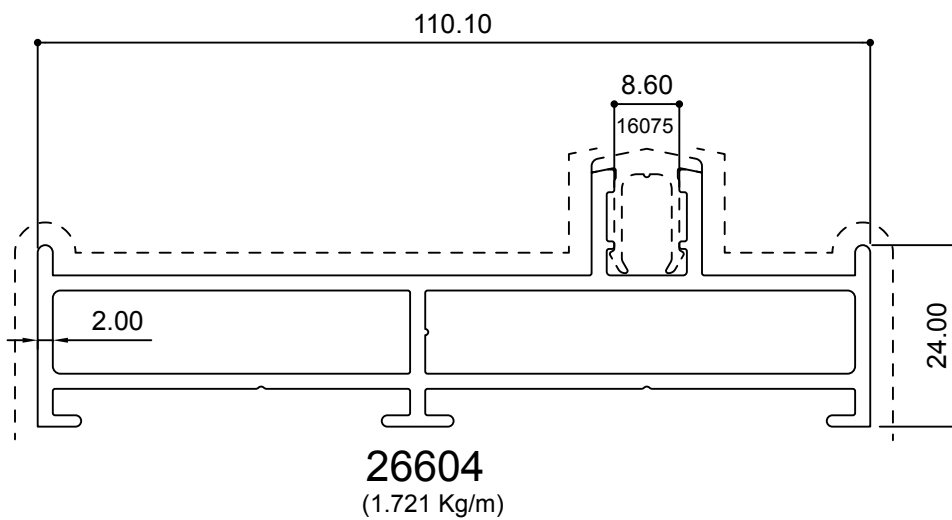
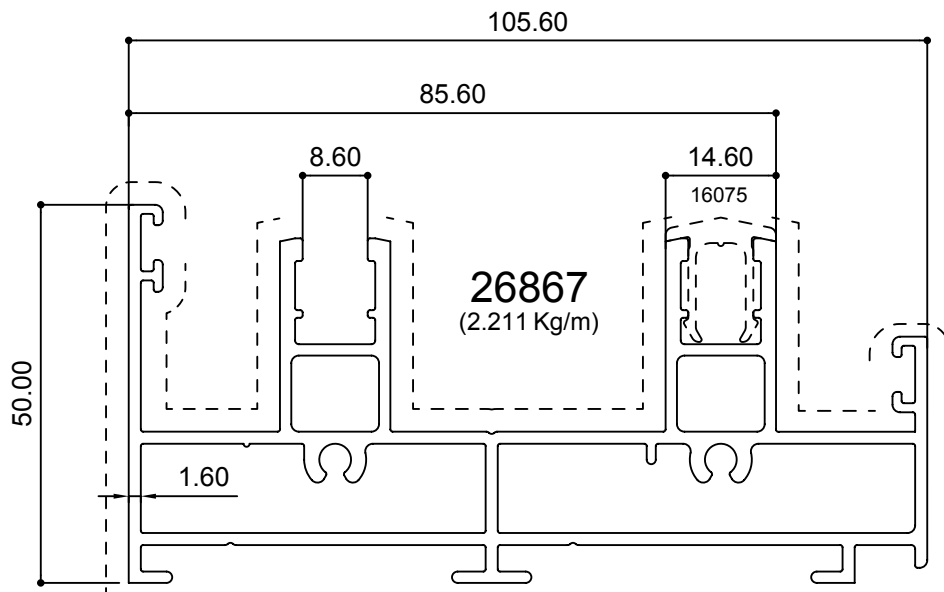
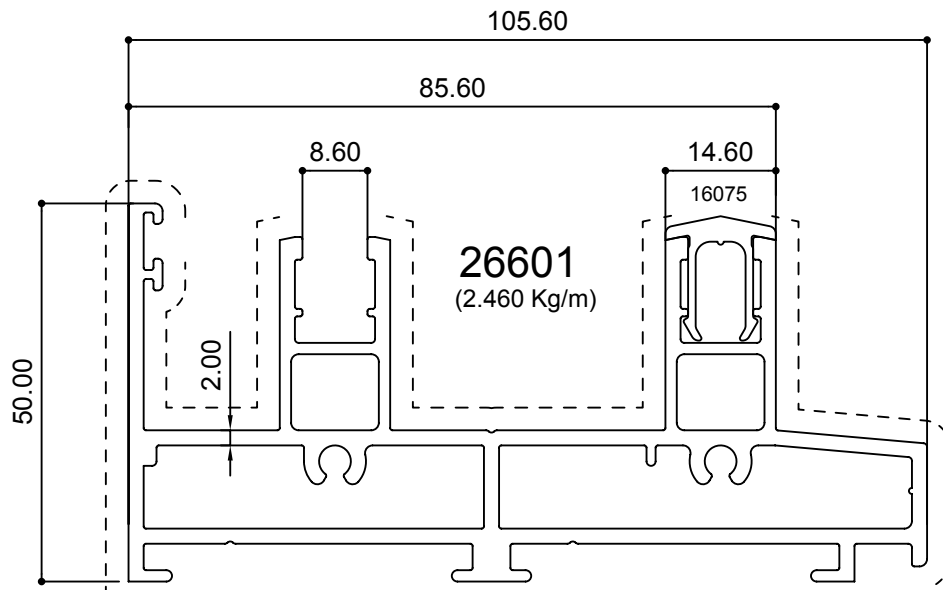

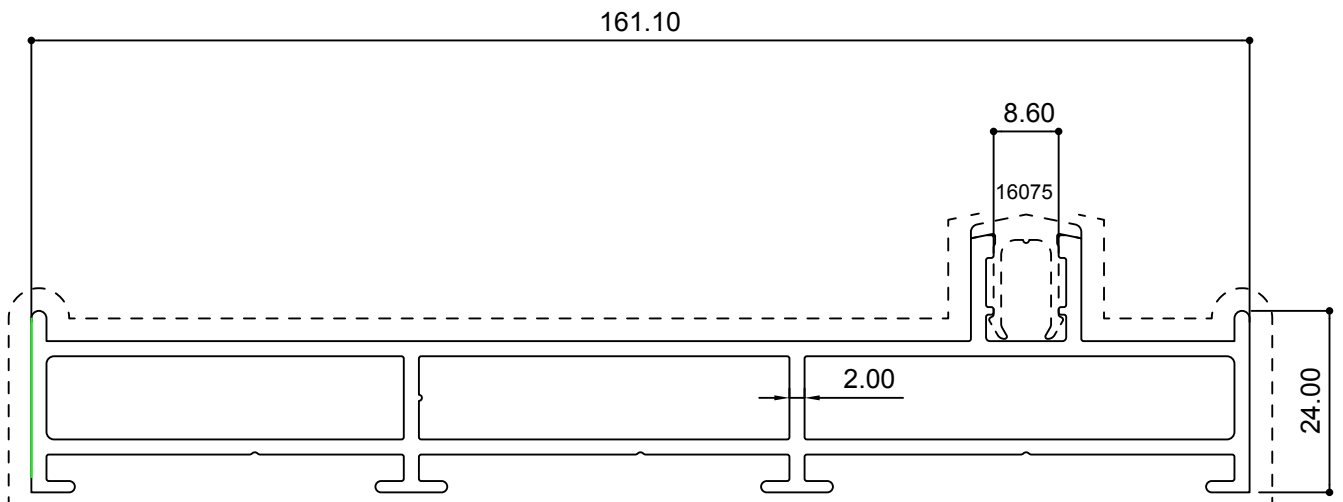
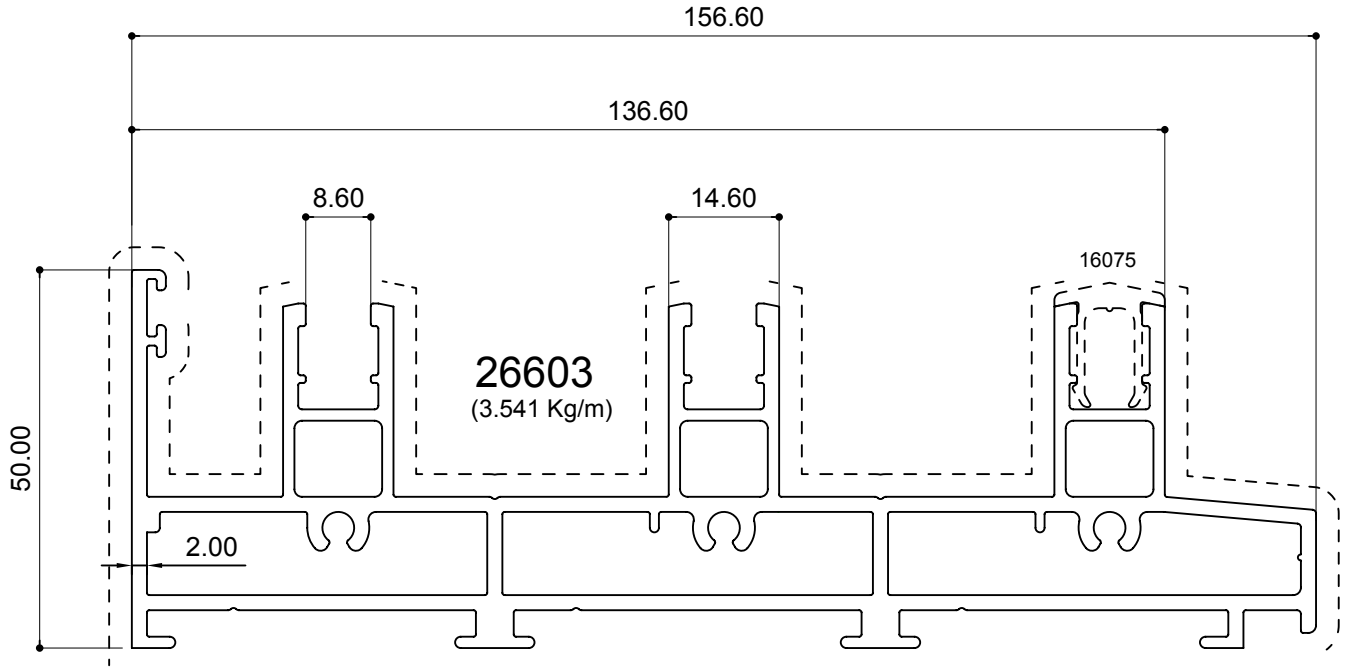

26602
(2.387 Kg/m)

N MINIMAL SERIES

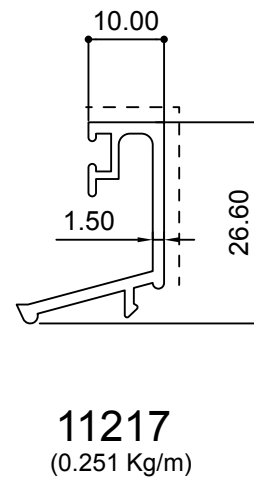
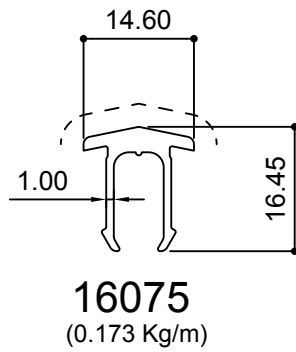
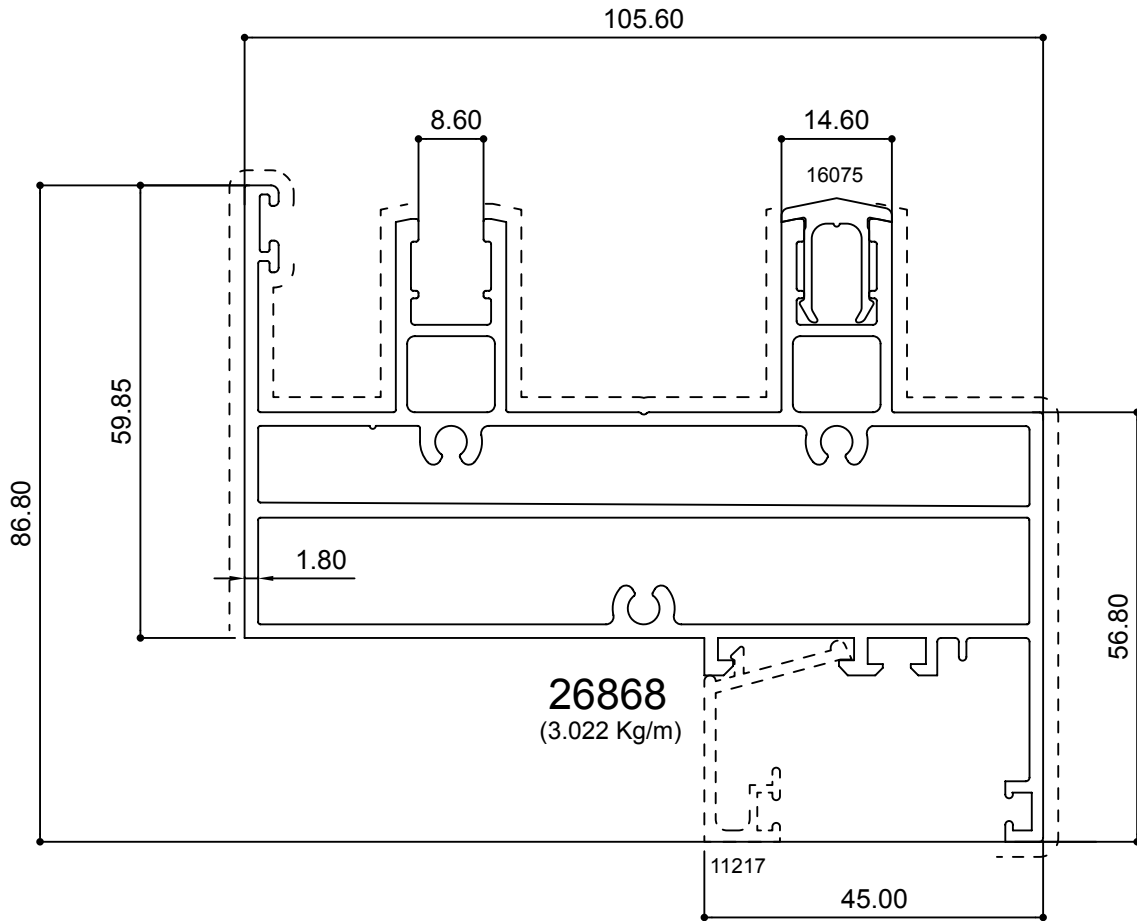

N MINIMAL SERIES

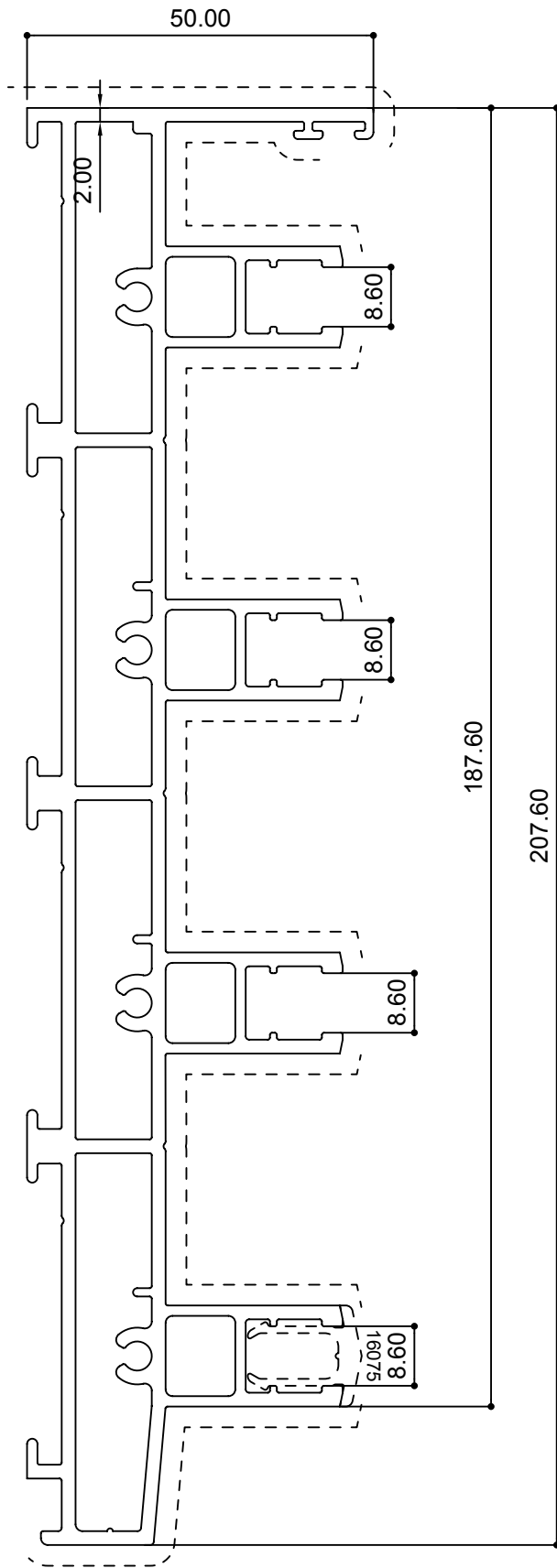

26597
(4.622 Kg/m)

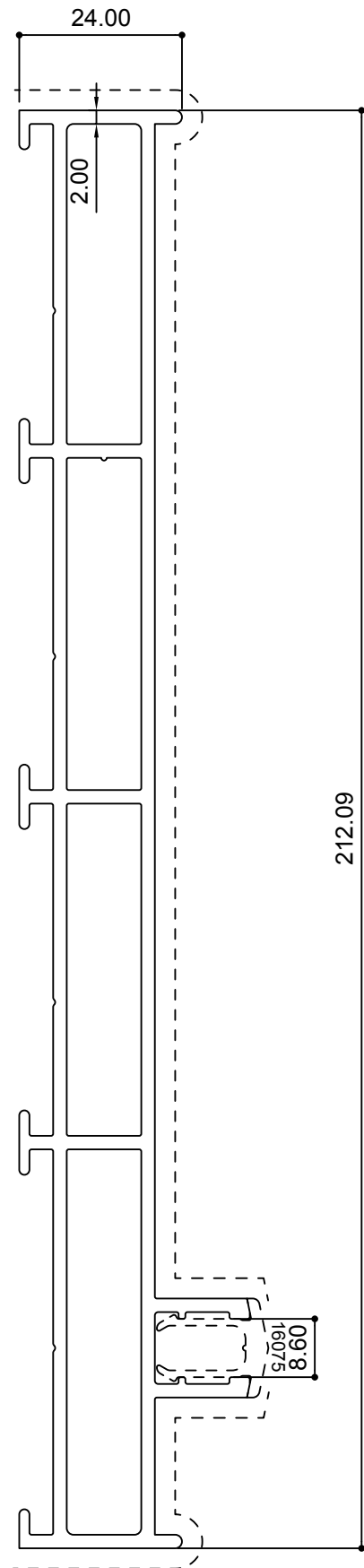

26598
(3.053 Kg/m)

N MINIMAL SERIES

27612
(7.048 Kg/m)

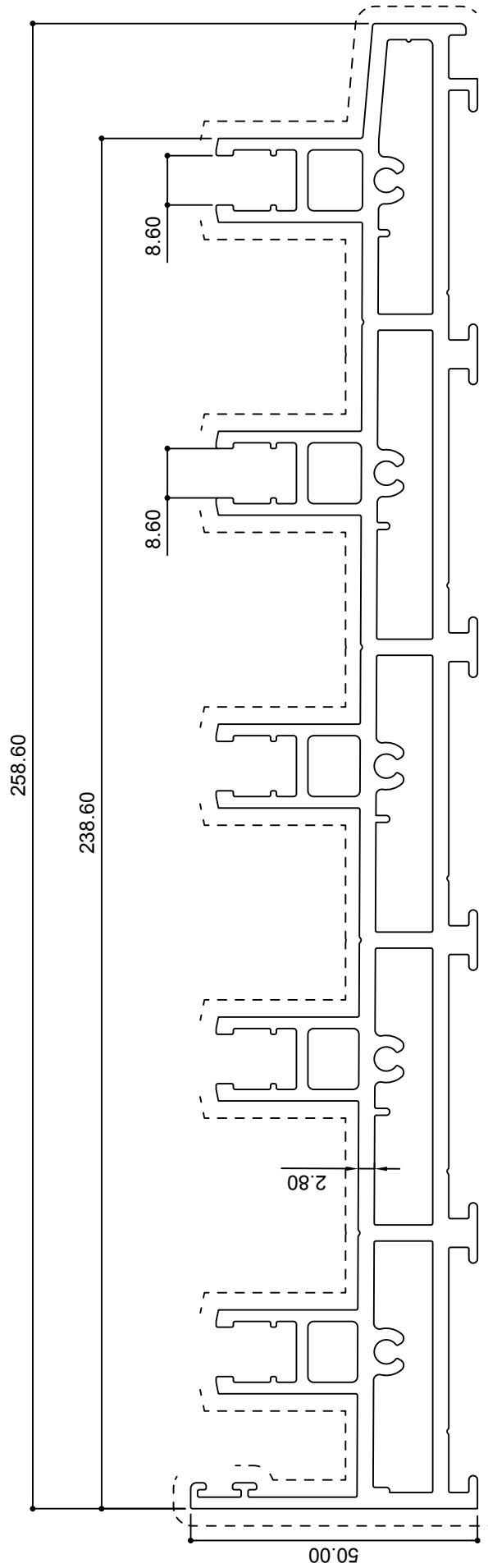

N MINIMAL SERIES

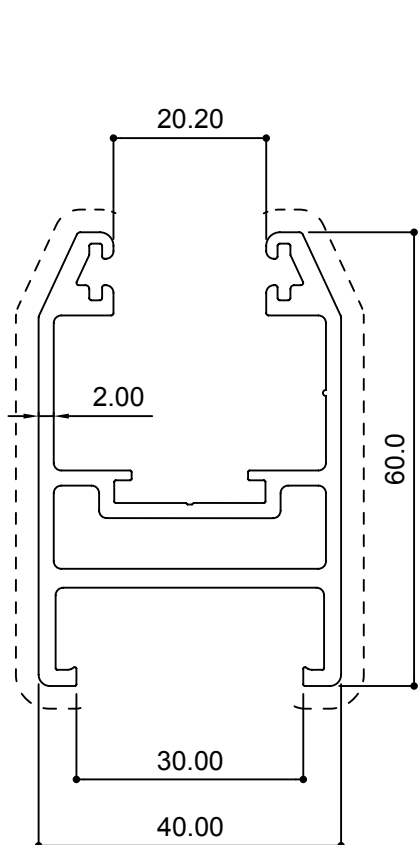

26599
1.391 Kg/m

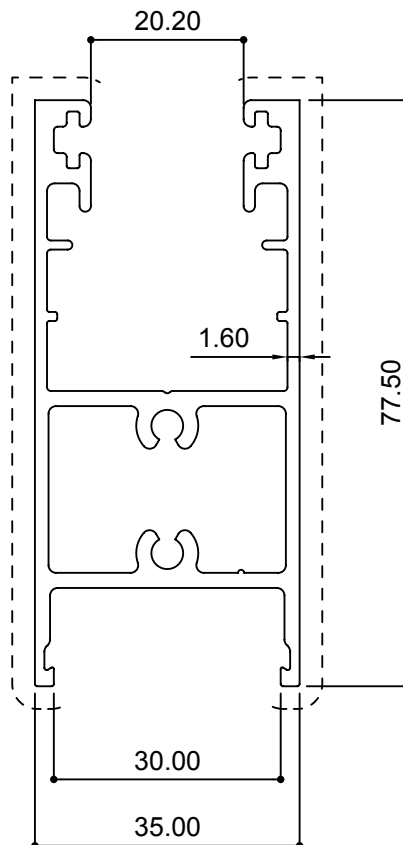

26600
1.479 Kg/m

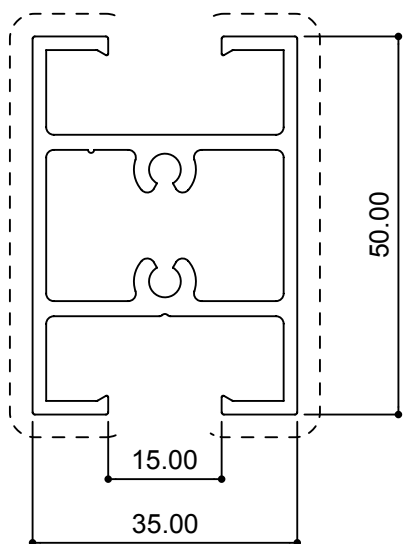

27569
1.137 Kg/m

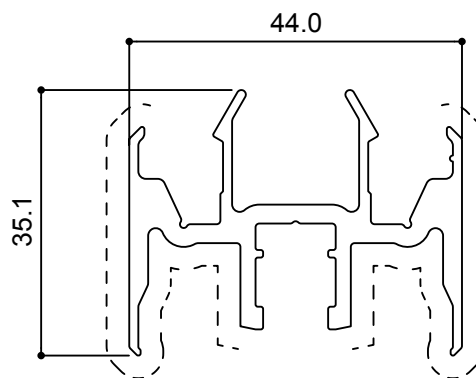

16073
(0.969 Kg/m)

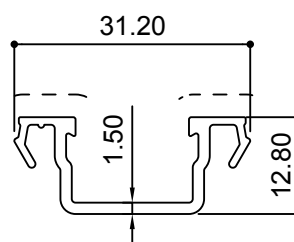

16074
(0.242 Kg/m)

N MINIMAL SERIES

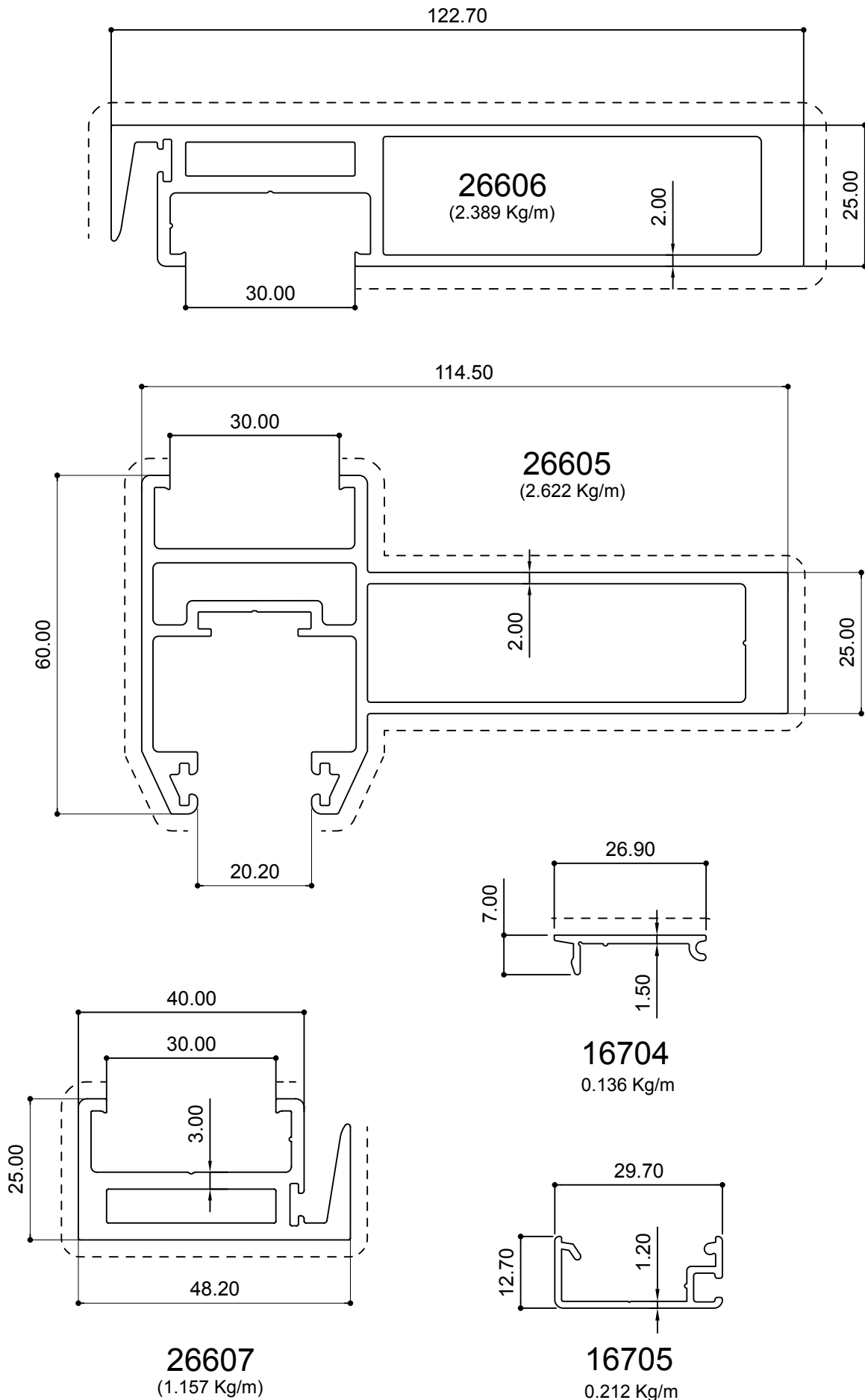

N MINIMAL SERIES

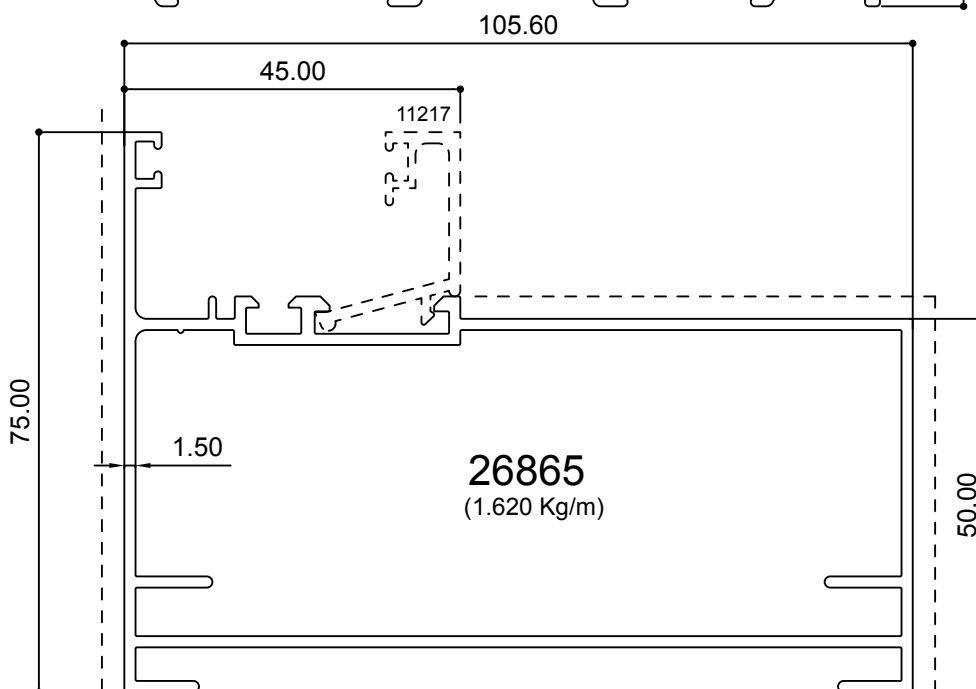
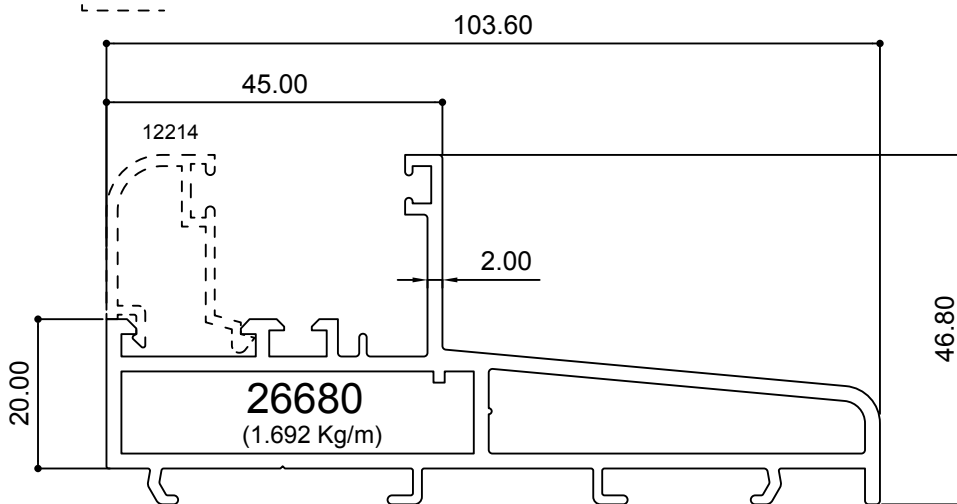
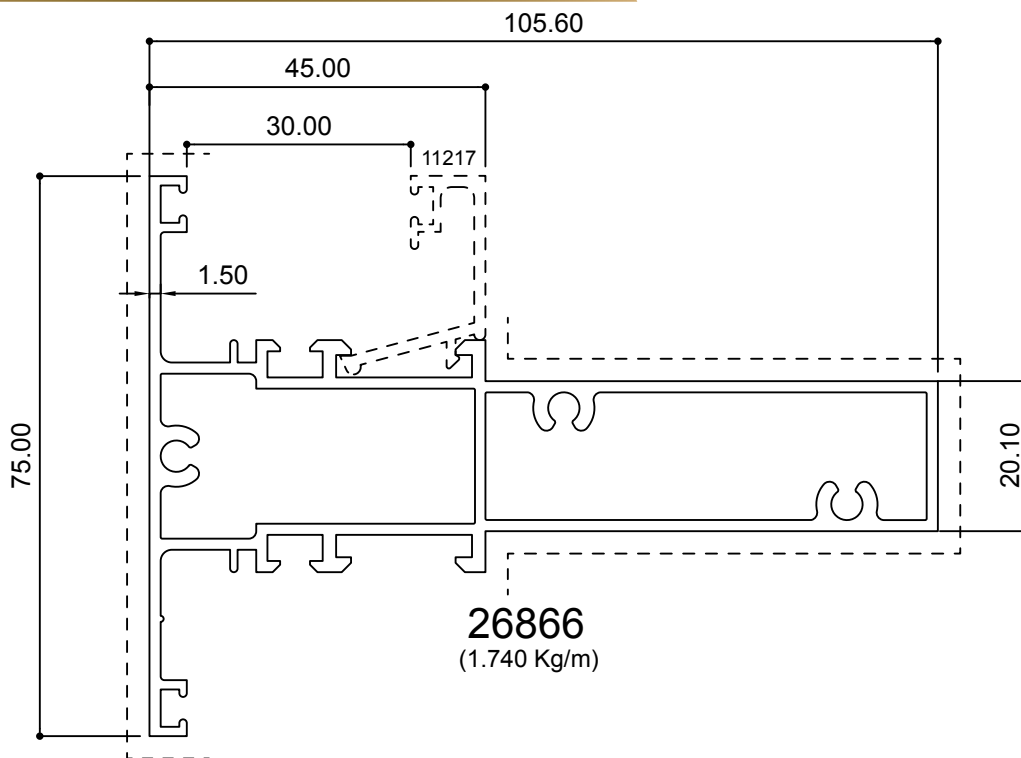



CHART A (EI = 14.71)

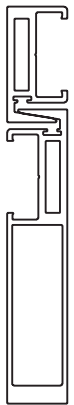

CHART B (EI = 107.82)

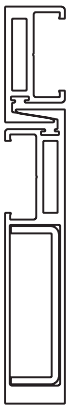

CHART C (EI = 143)



CHART D (EI = 200.93)

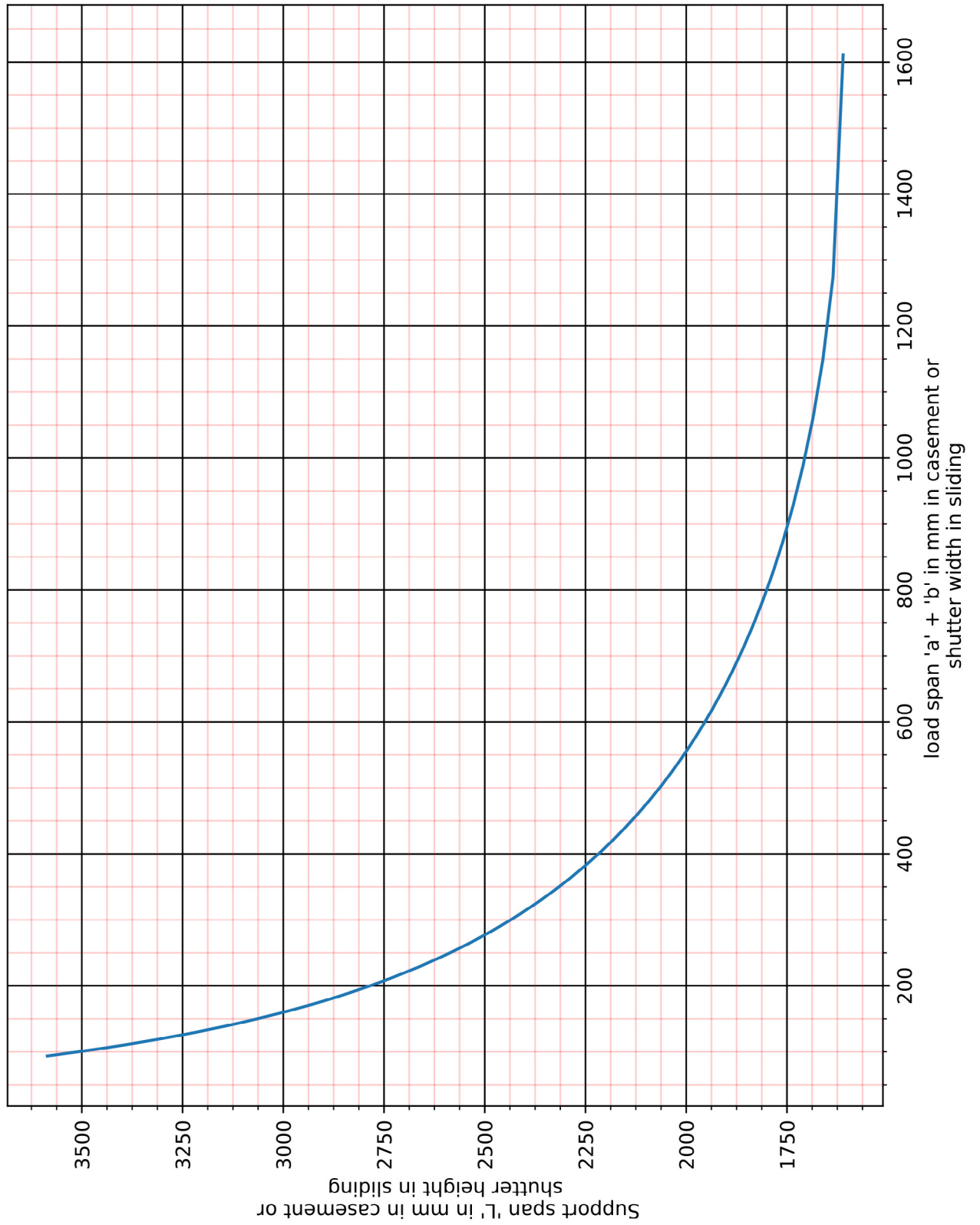

CHART E (EI = 236.17)

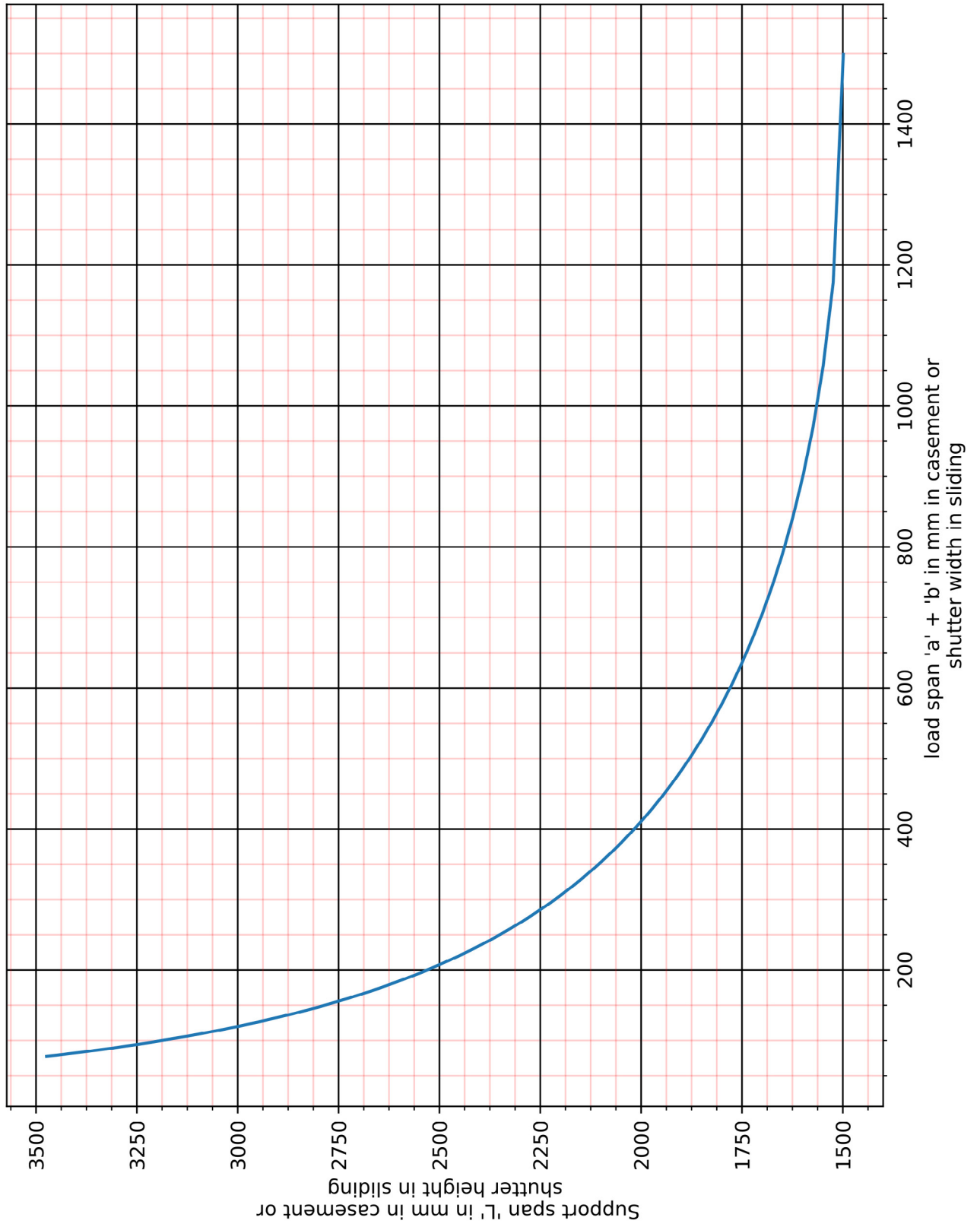

CHART F (EI = 271.41)

Size Selection Chart - CHART A - 1500 Pa
at 1500 Pa & EI = 14.71 x 10⁹ N-mm²



Size Selection Chart - CHART A - 2000 Pa
at 2000 Pa & EI = 14.71 x 10⁹ N-mm²



Size Selection Chart - CHART A - 3000 Pa
at 3000 Pa & EI = 14.71 x 10⁹ N-mm²

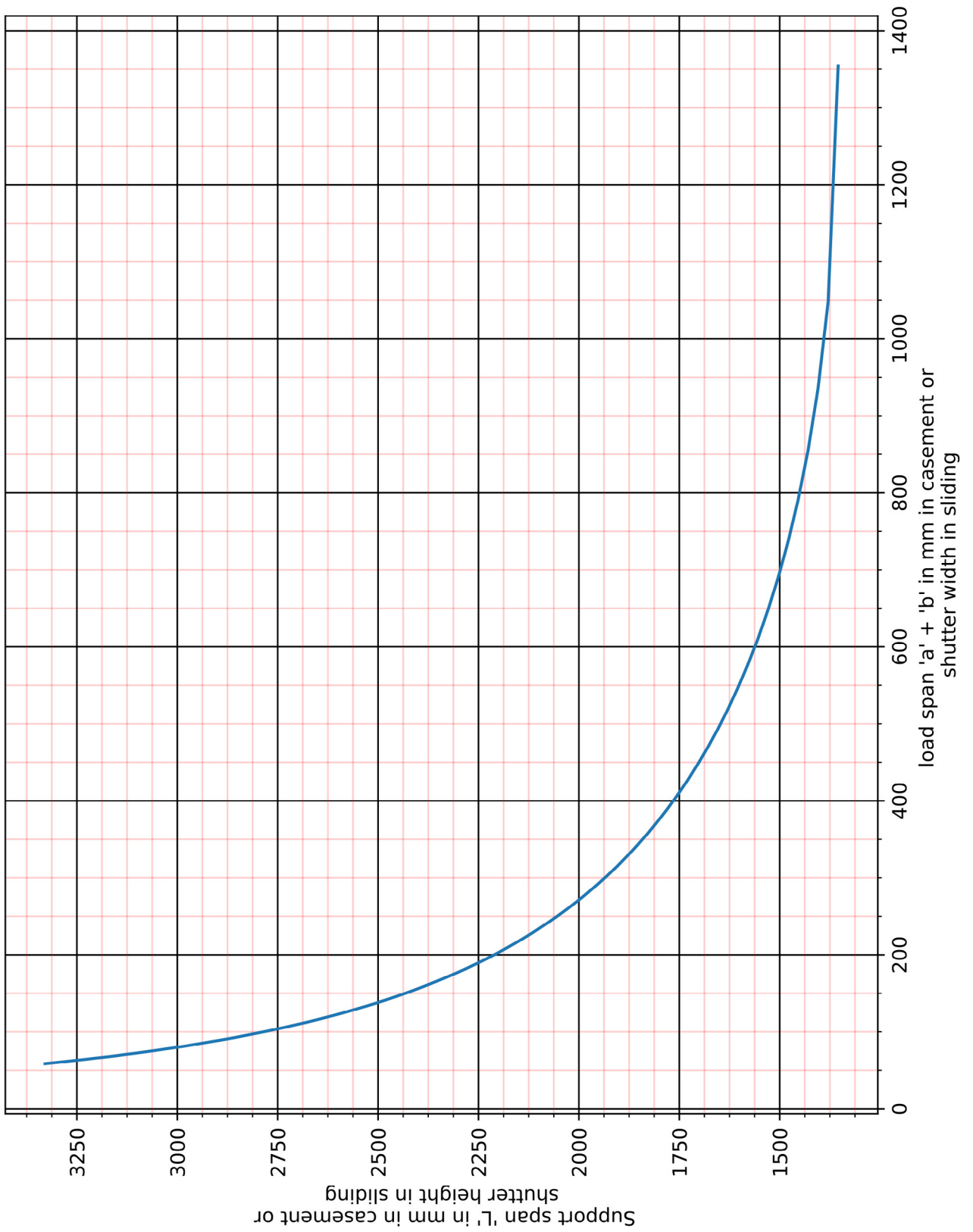

Size Selection Chart - CHART A - 2500 Pa
at 2500 Pa & EI = 14.71 x 10⁹ N-mm²

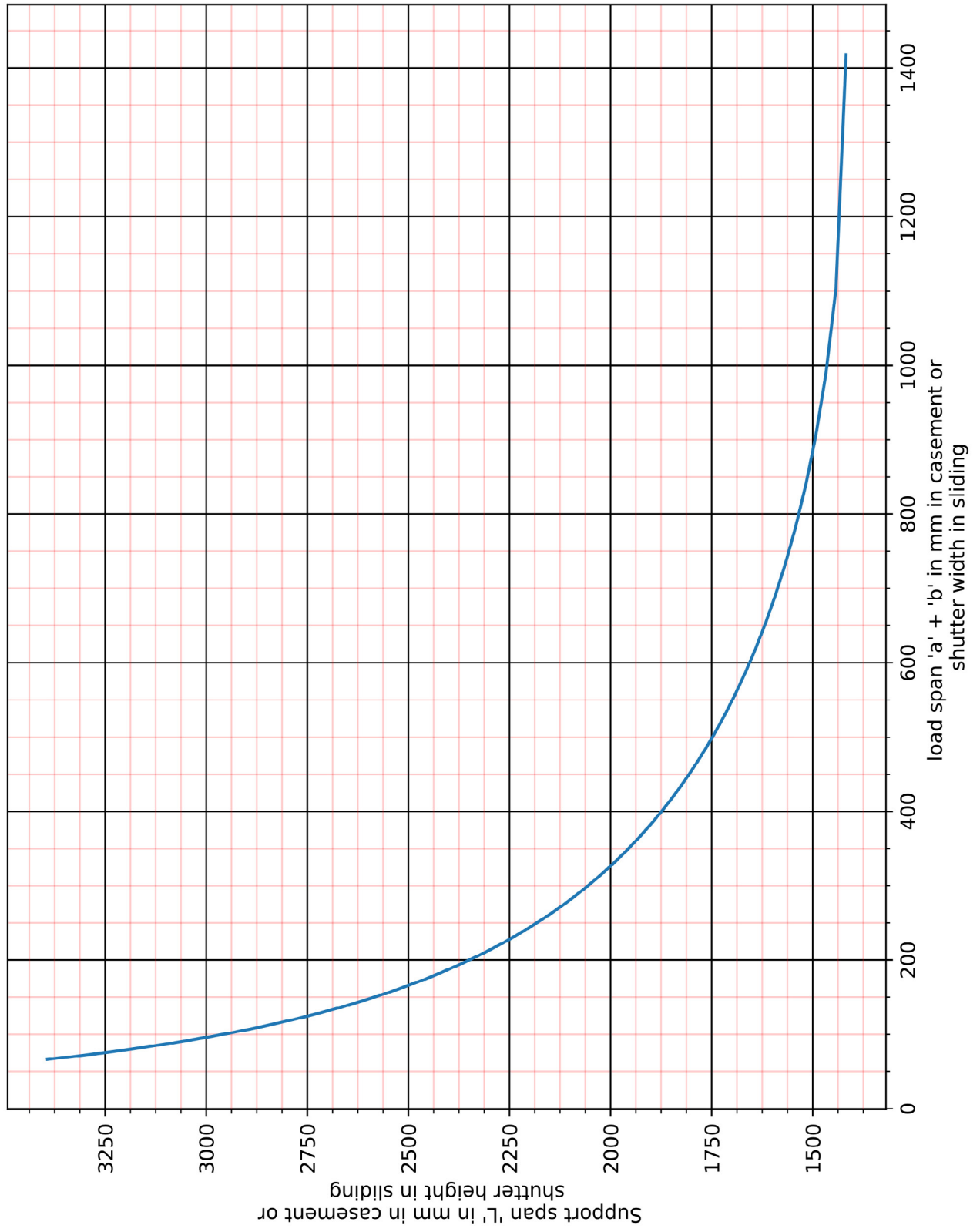

Size Selection Chart - CHART B - 1000 Pa
at 1000 Pa & EI = 107.82 x 10⁹ N-mm²

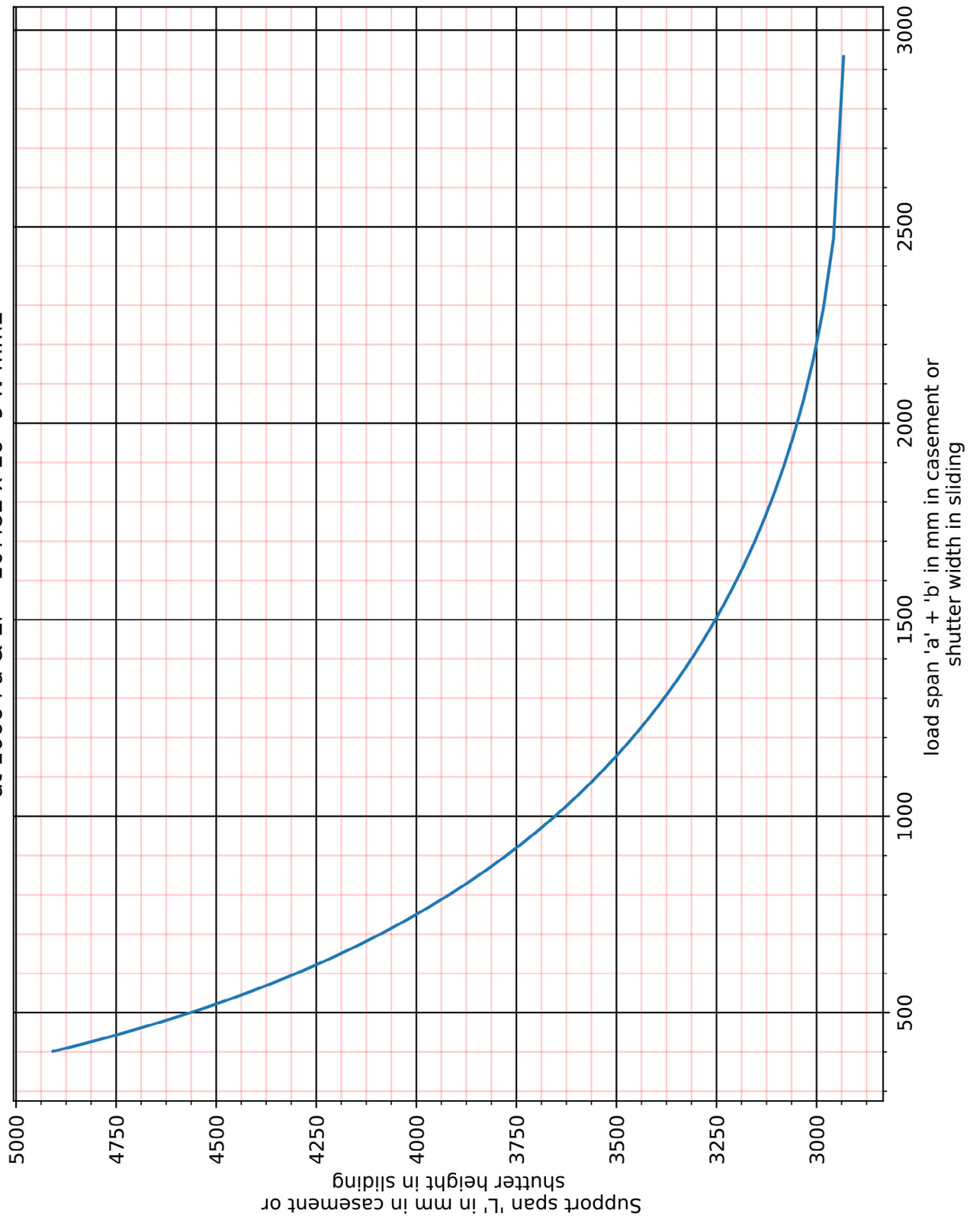

Size Selection Chart - CHART B - 1500 Pa
at 1500 Pa & EI = 107.82 x 10⁹ N-mm²

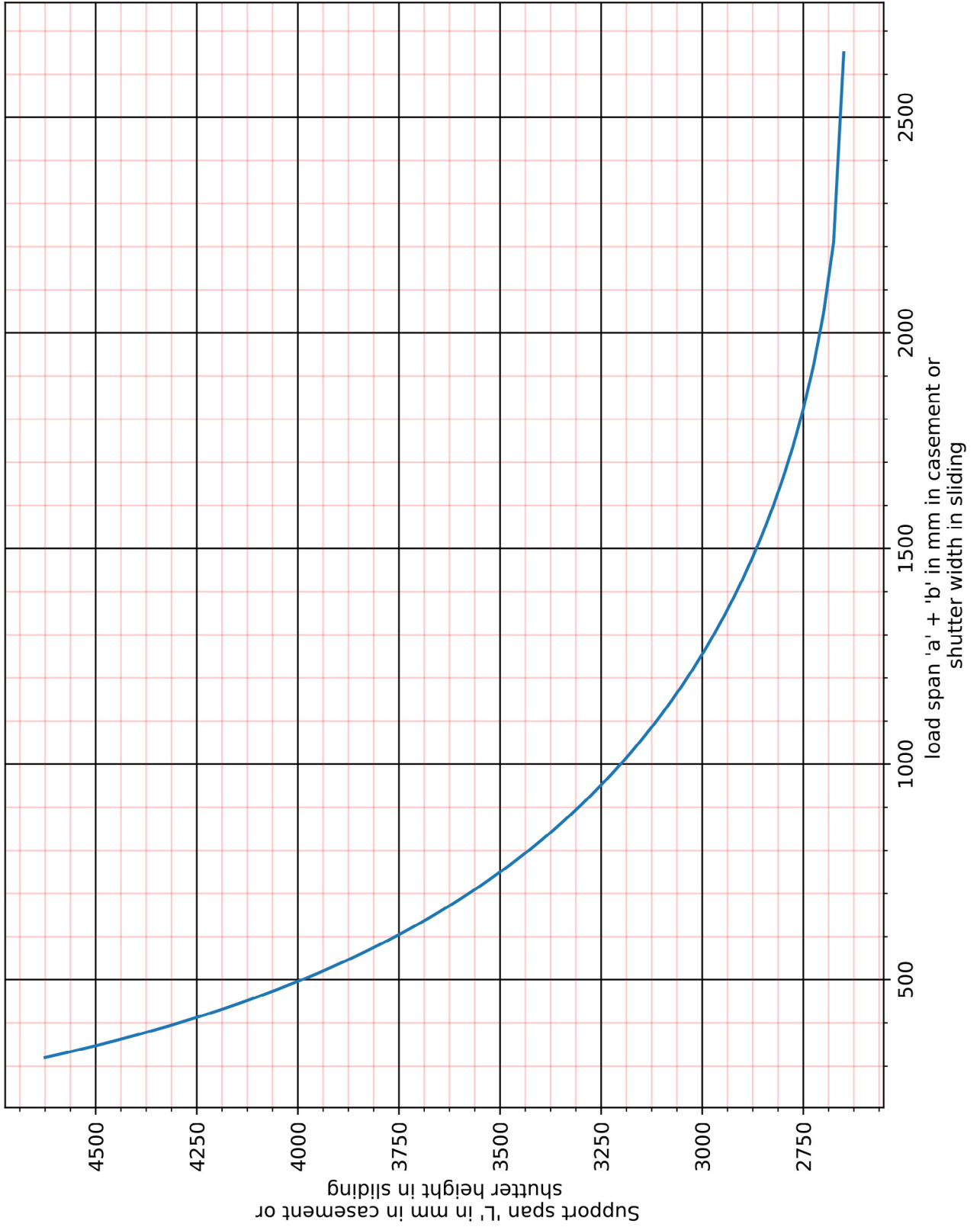

Size Selection Chart - CHART B - 2500 Pa
at 2500 Pa & EI = 107.82 x 10⁹ N-mm²

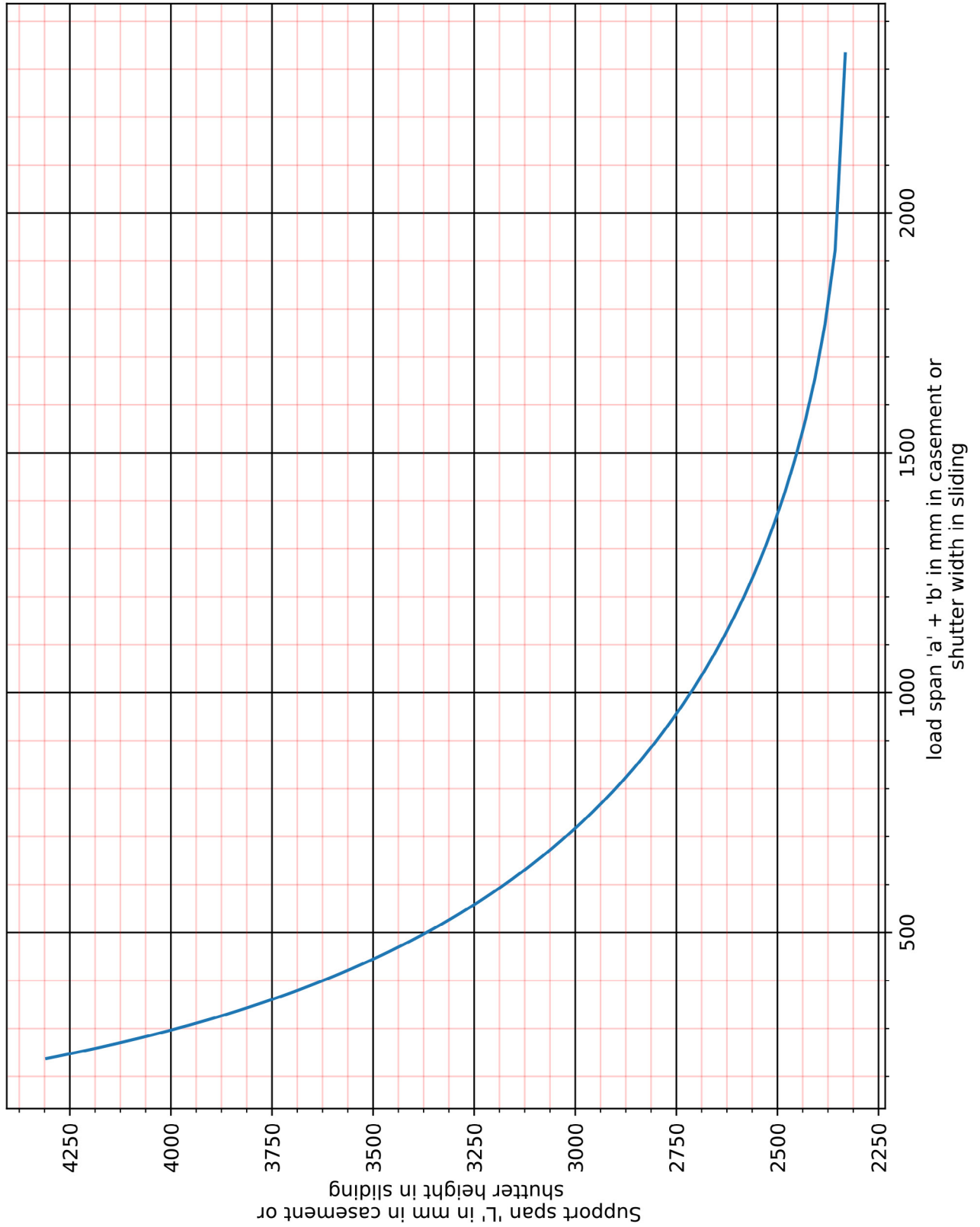

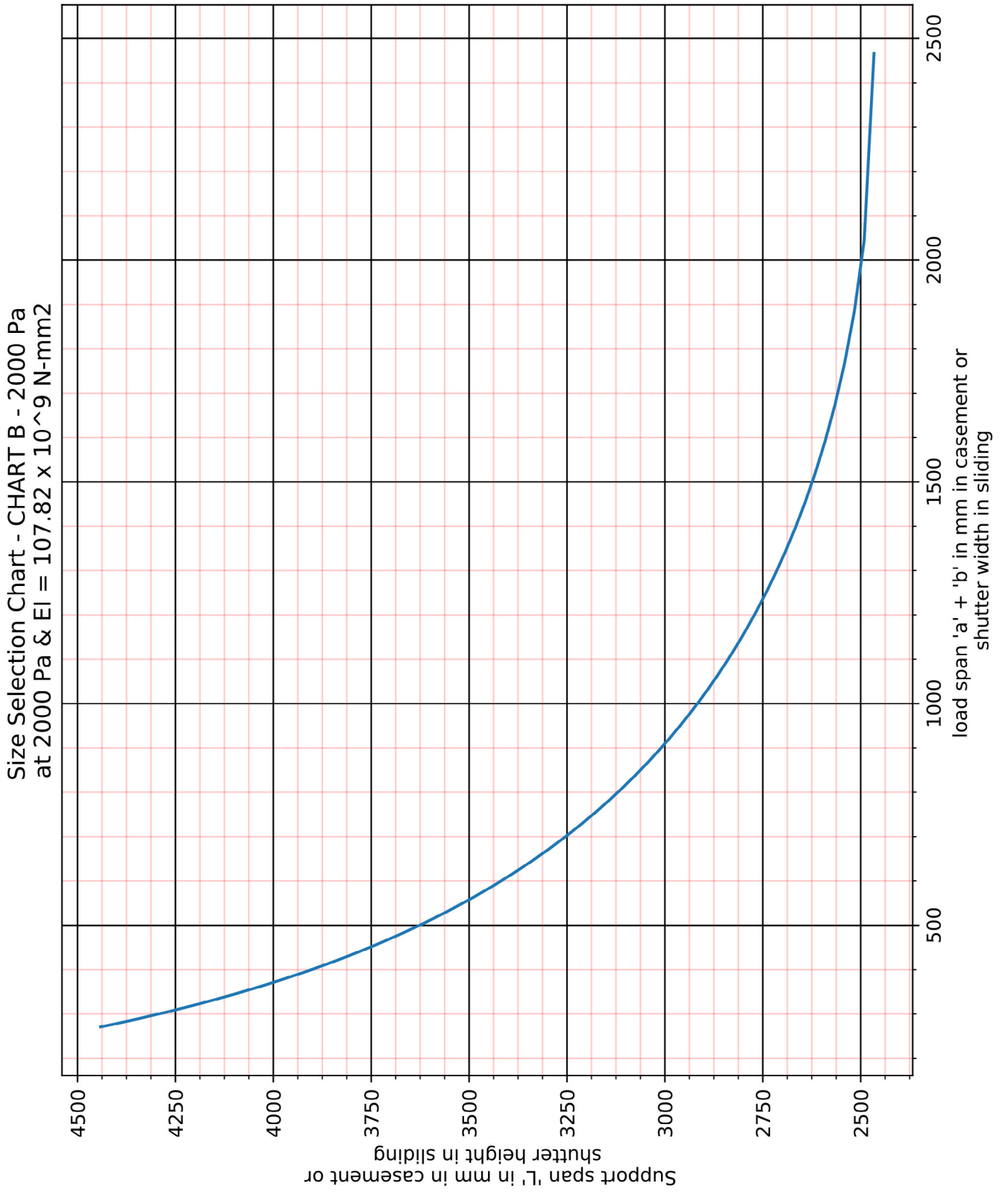

Size Selection Chart - CHART C - 1000 Pa
at 1000 Pa & EI = 143.0 x 10⁹ N-mm²

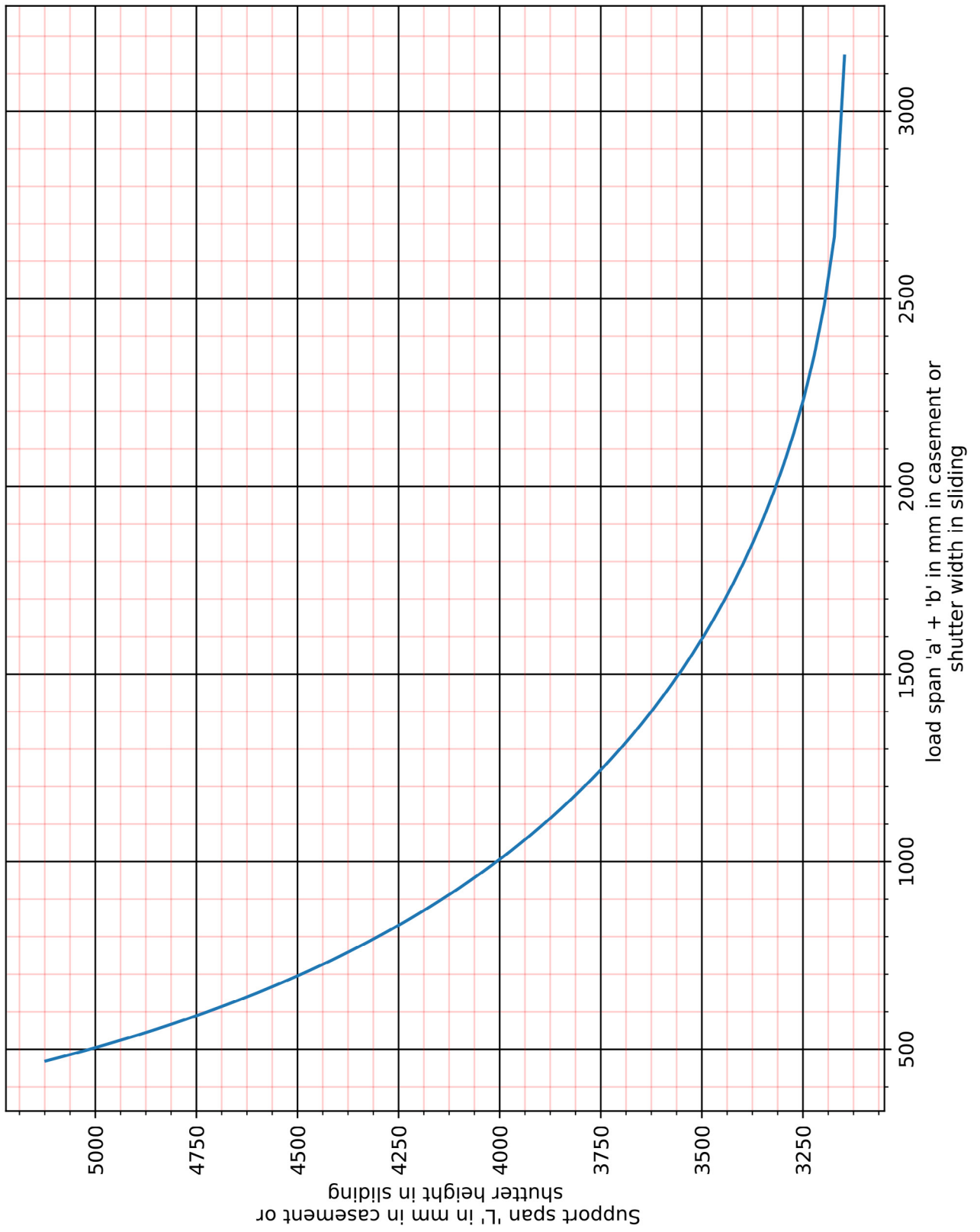

Size Selection Chart - CHART B - 3000 Pa
at 3000 Pa & EI = 107.82 x 10⁹ N-mm²

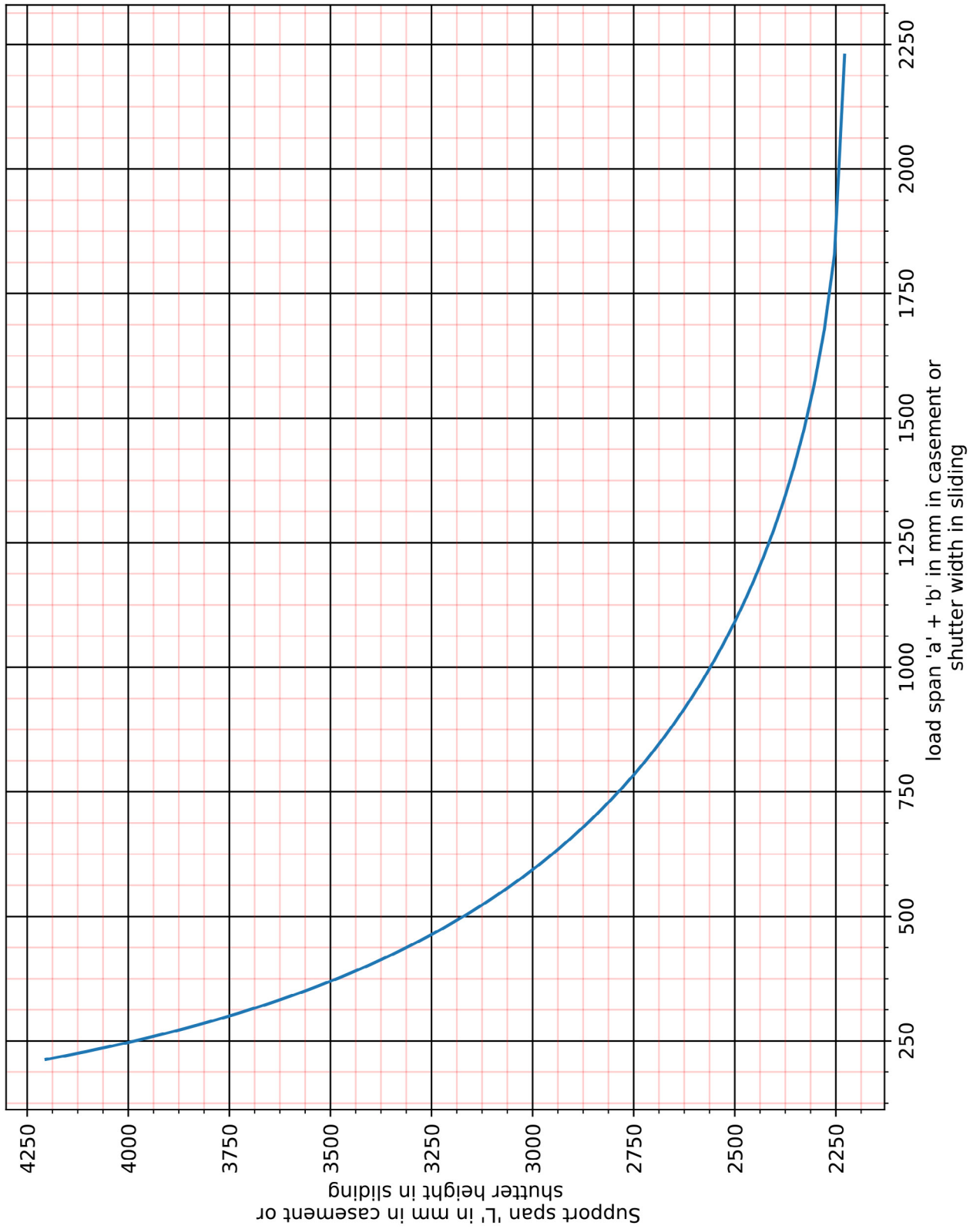

Size Selection Chart - CHART C - 2000 Pa
at 2000 Pa & EI = 143.0 x 10⁹ N-mm²

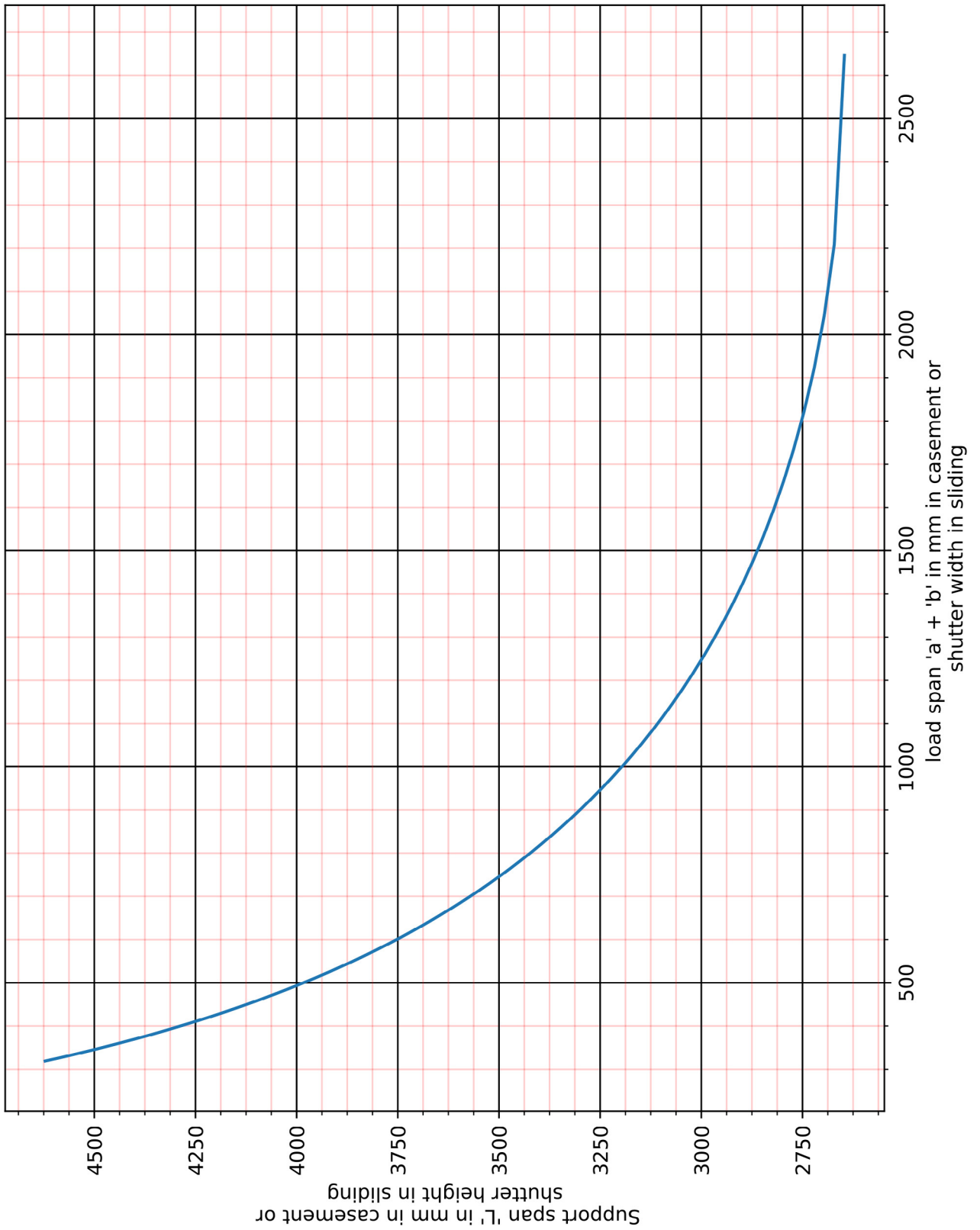

Size Selection Chart - CHART C - 1500 Pa
at 1500 Pa & EI = 143.0 x 10⁹ N-mm²

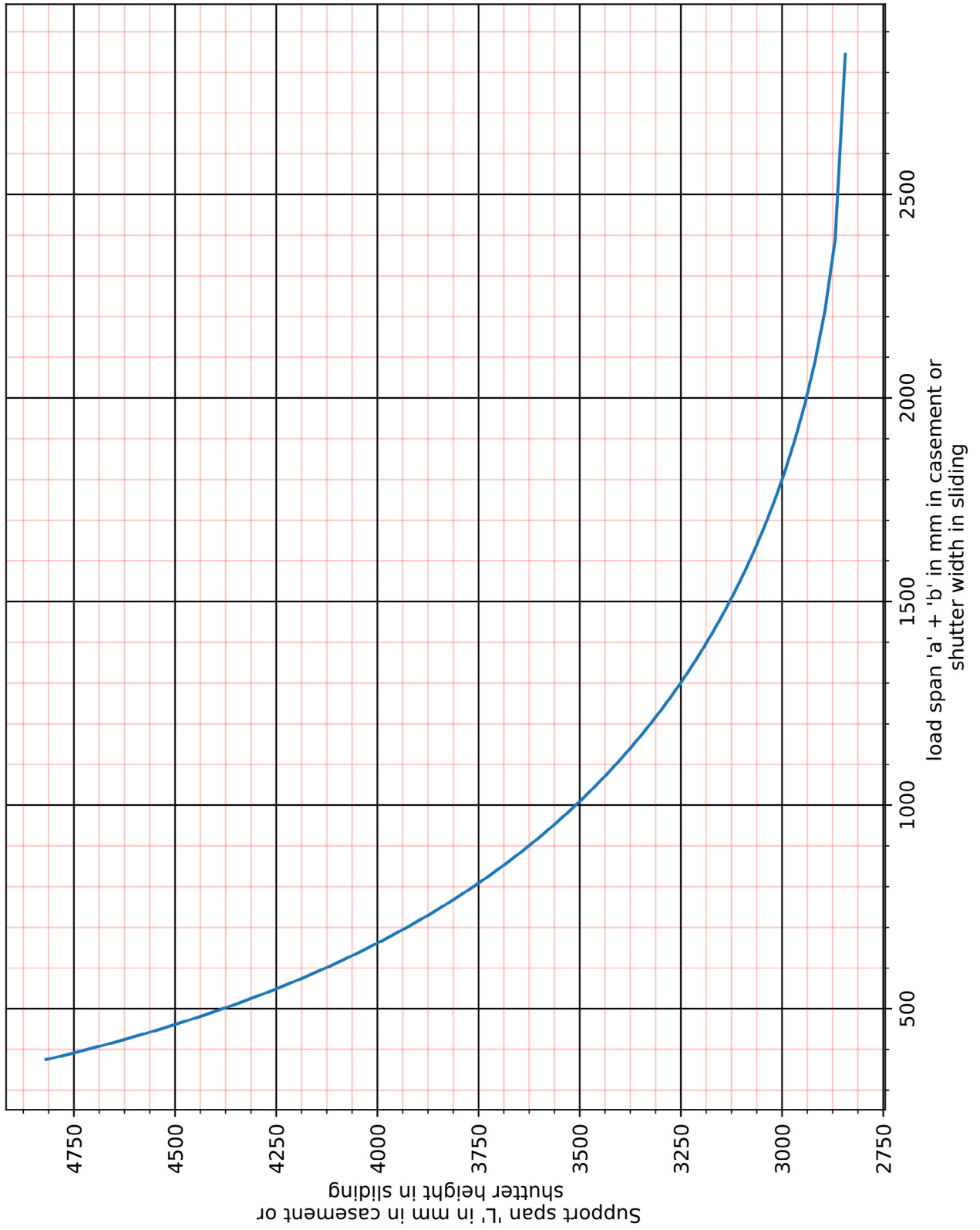

Size Selection Chart - CHART C - 3000 Pa
at 3000 Pa & EI = 143.0 x 10⁹ N-mm²

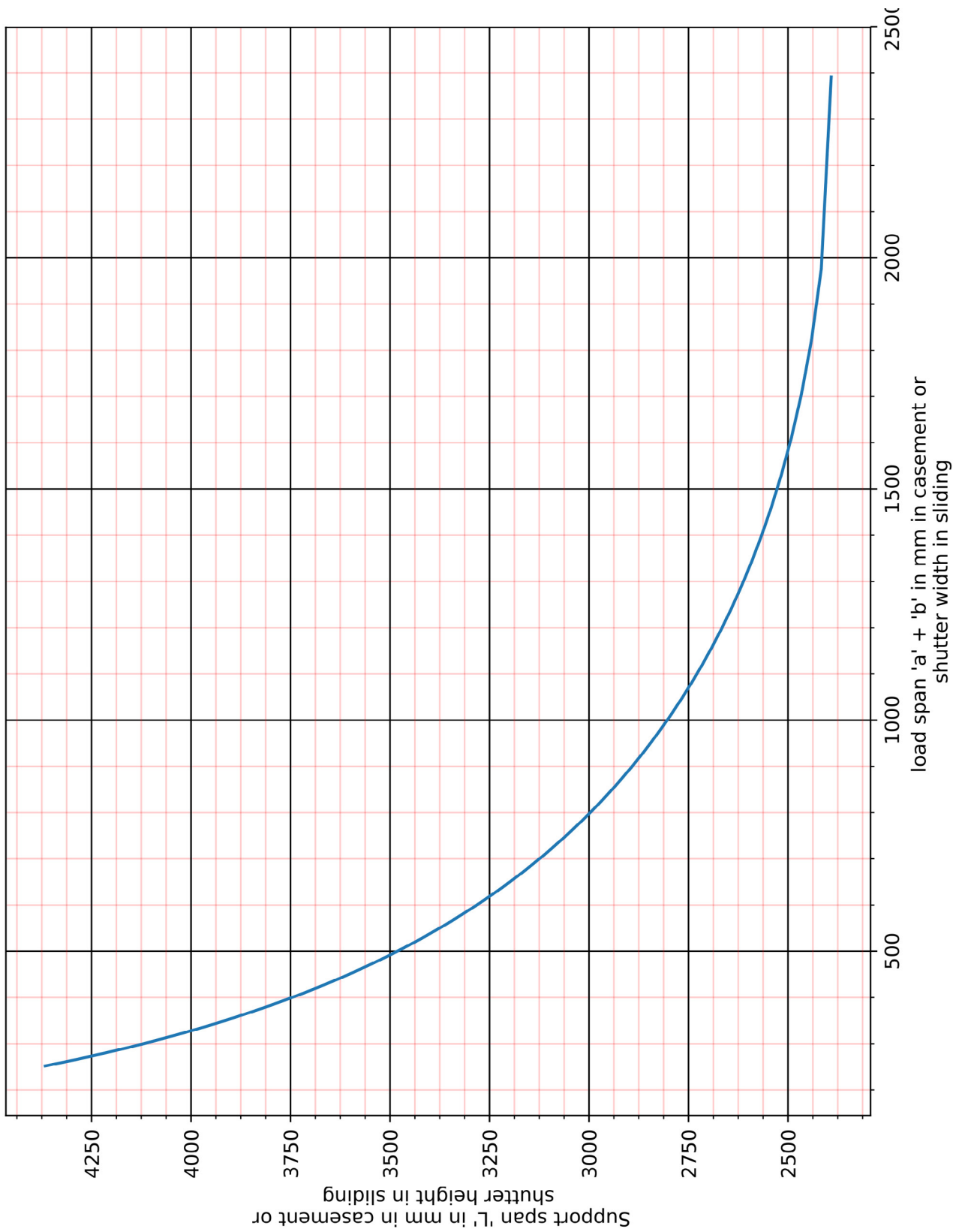

Size Selection Chart - CHART C - 2500 Pa
at 2500 Pa & EI = 143.0 x 10⁹ N-mm²

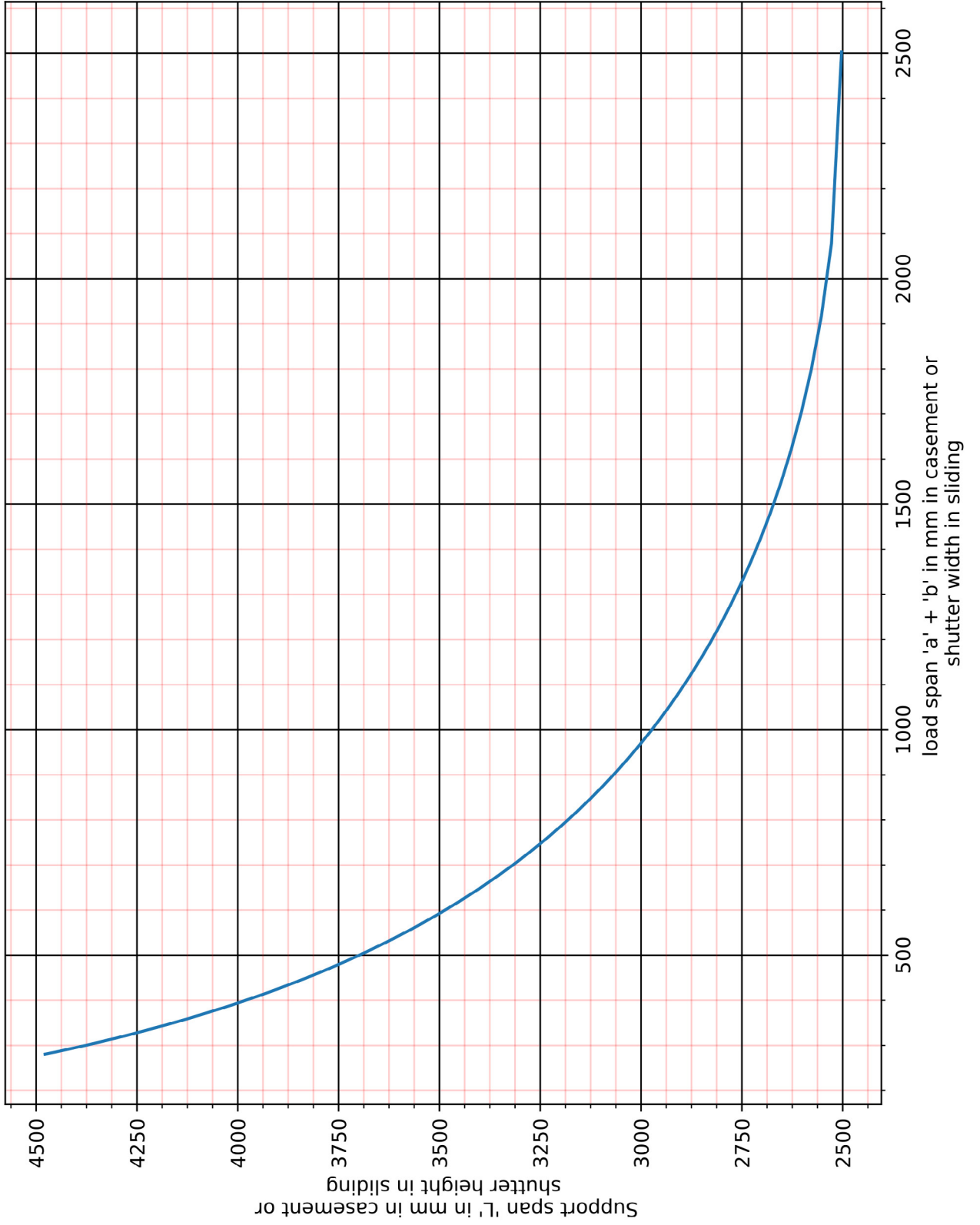

Size Selection Chart - GRAPH D - 1500 Pa
at 1500 Pa & EI = 200.93 x 10⁹ N-mm²

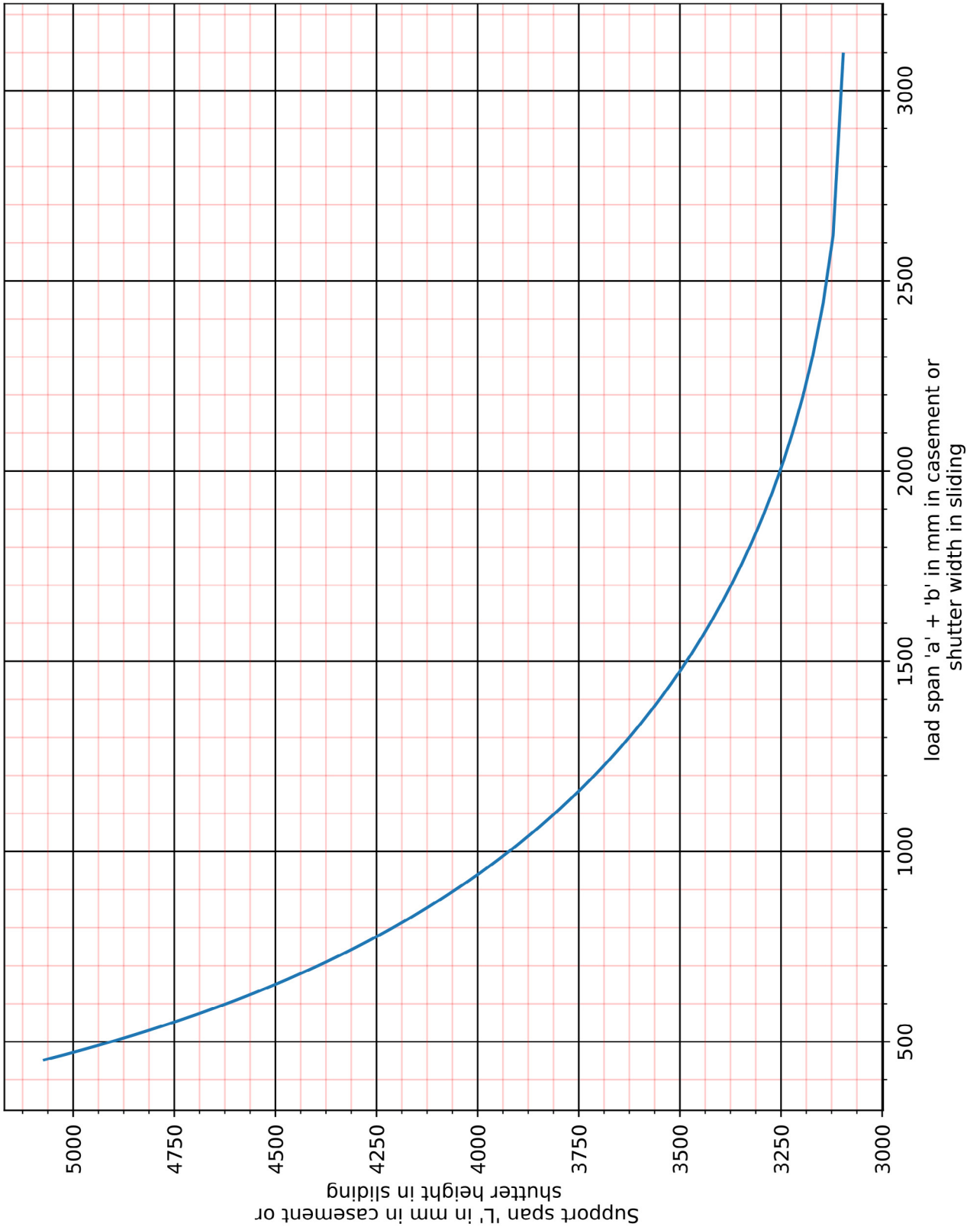

Size Selection Chart - GRAPH D - 1000 Pa
at 1000 Pa & EI = 200.93 x 10⁹ N-mm²

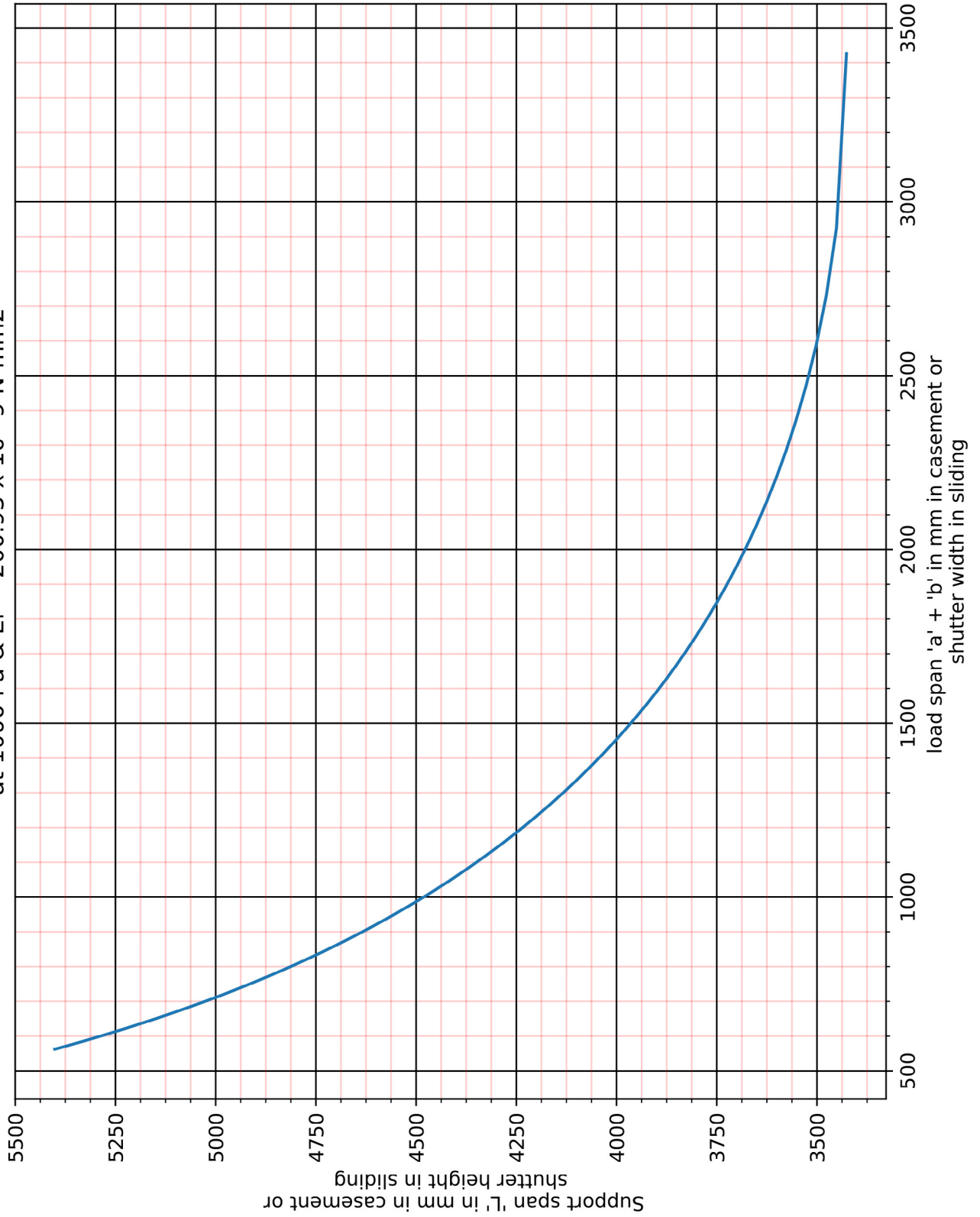

Size Selection Chart - GRAPH D - 2500 Pa
at 2500 Pa & EI = 200.93 x 10⁹ N-mm²

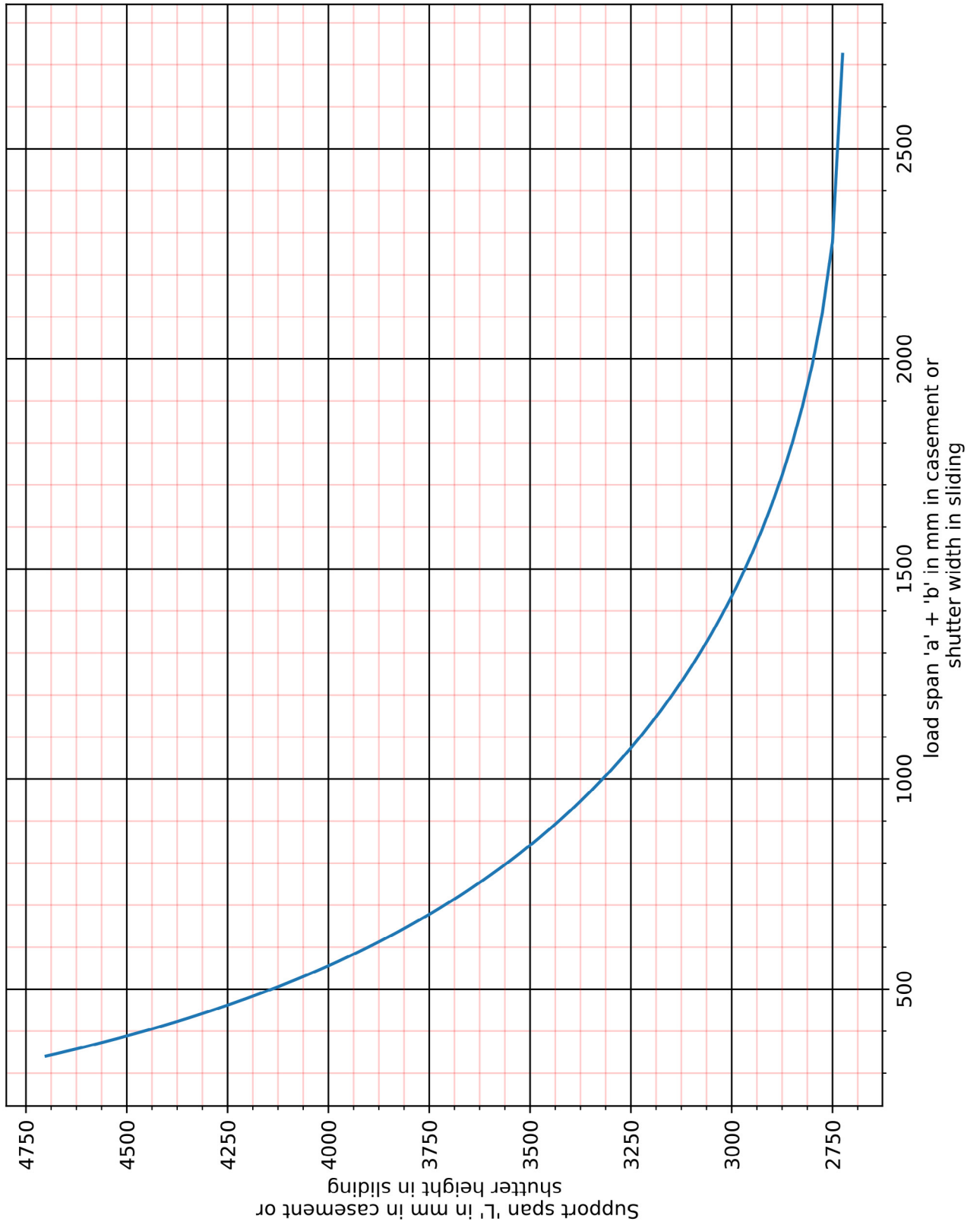

Size Selection Chart - GRAPH D - 2000 Pa
at 2000 Pa & EI = 200.93 x 10⁹ N-mm²

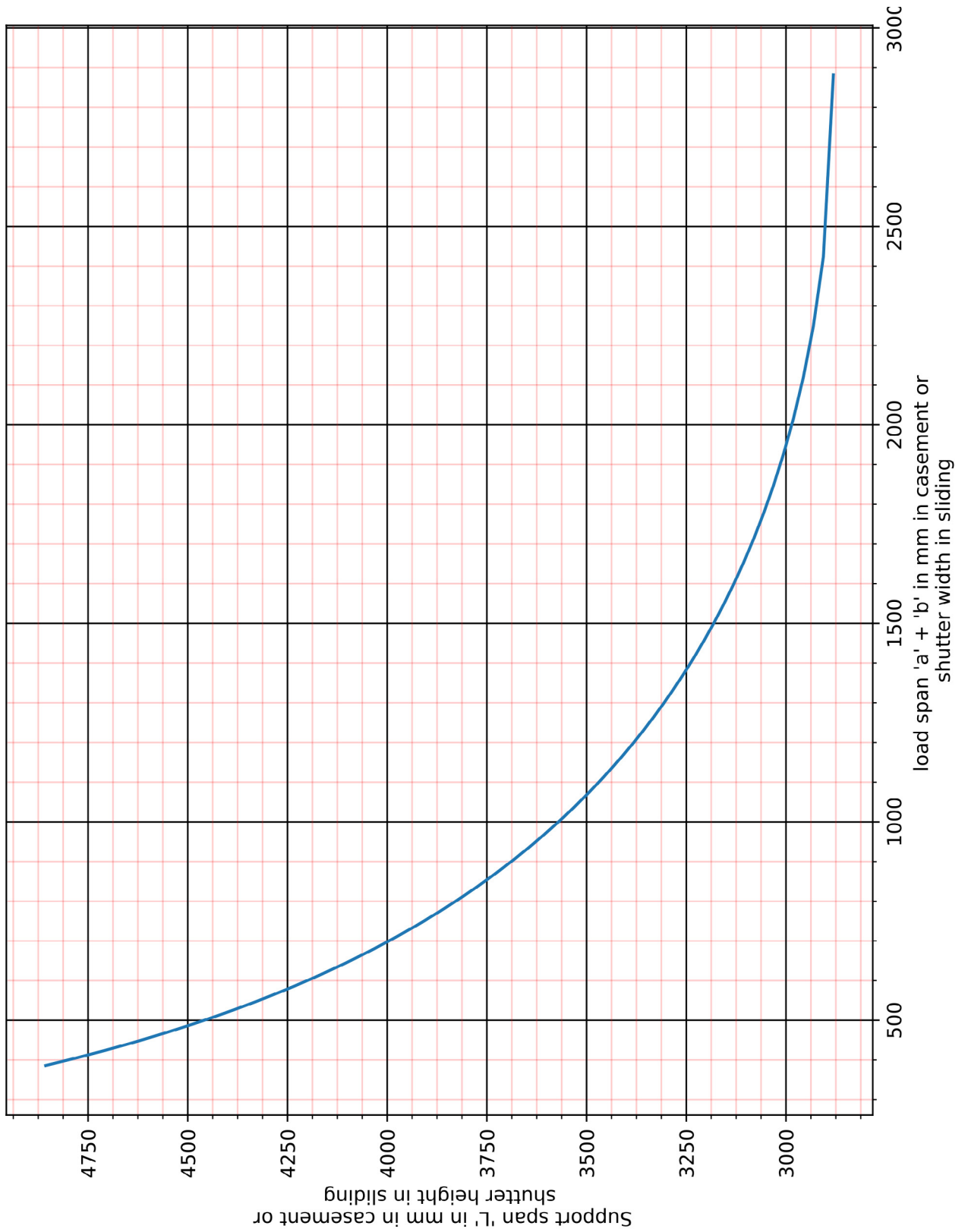

Size Selection Chart - CHART E - 1000 Pa
at 1000 Pa & EI = 236.17 x 10⁹ N-mm²

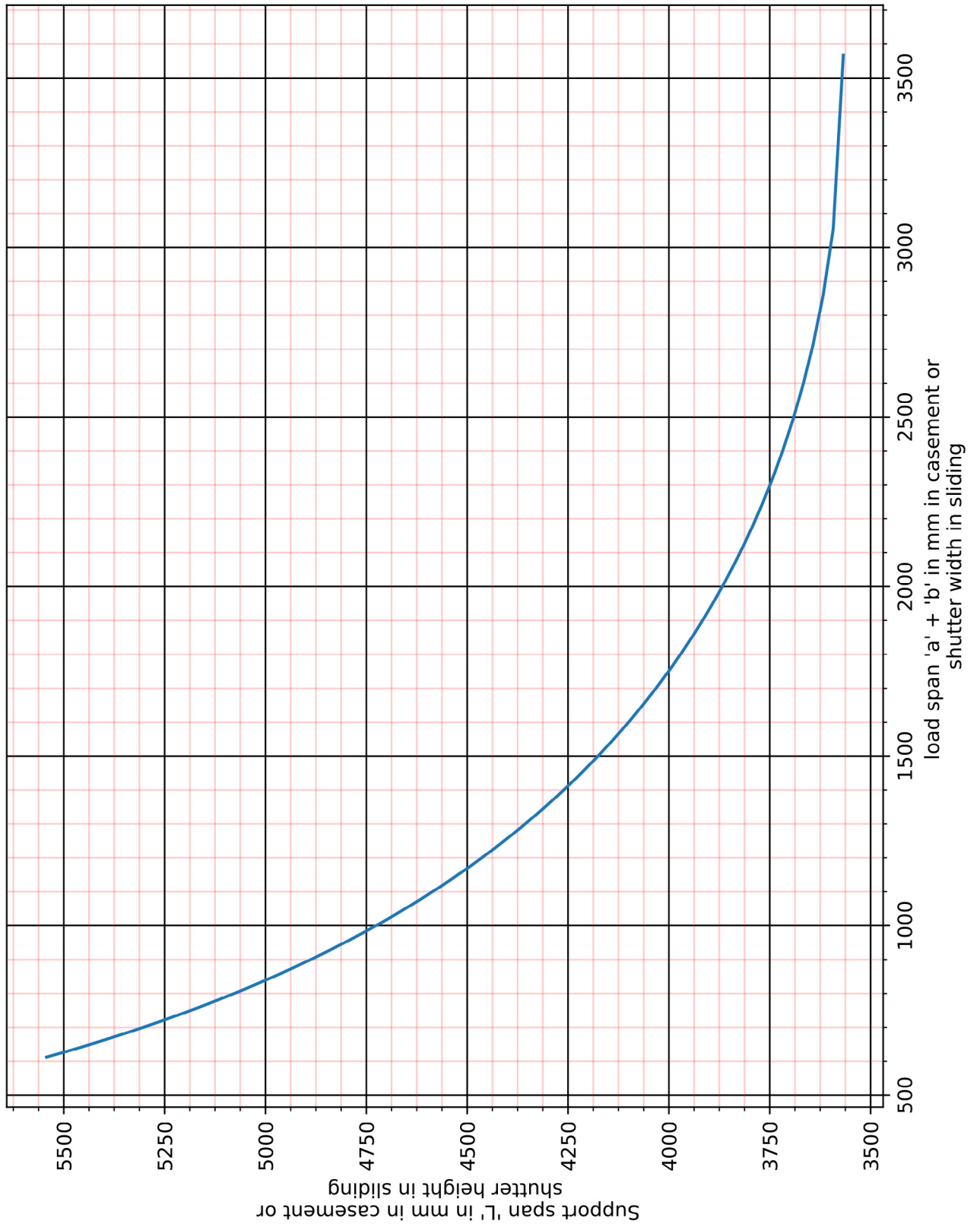

Size Selection Chart - GRAPH D - 3000 Pa
at 3000 Pa & EI = 200.93 x 10⁹ N-mm²

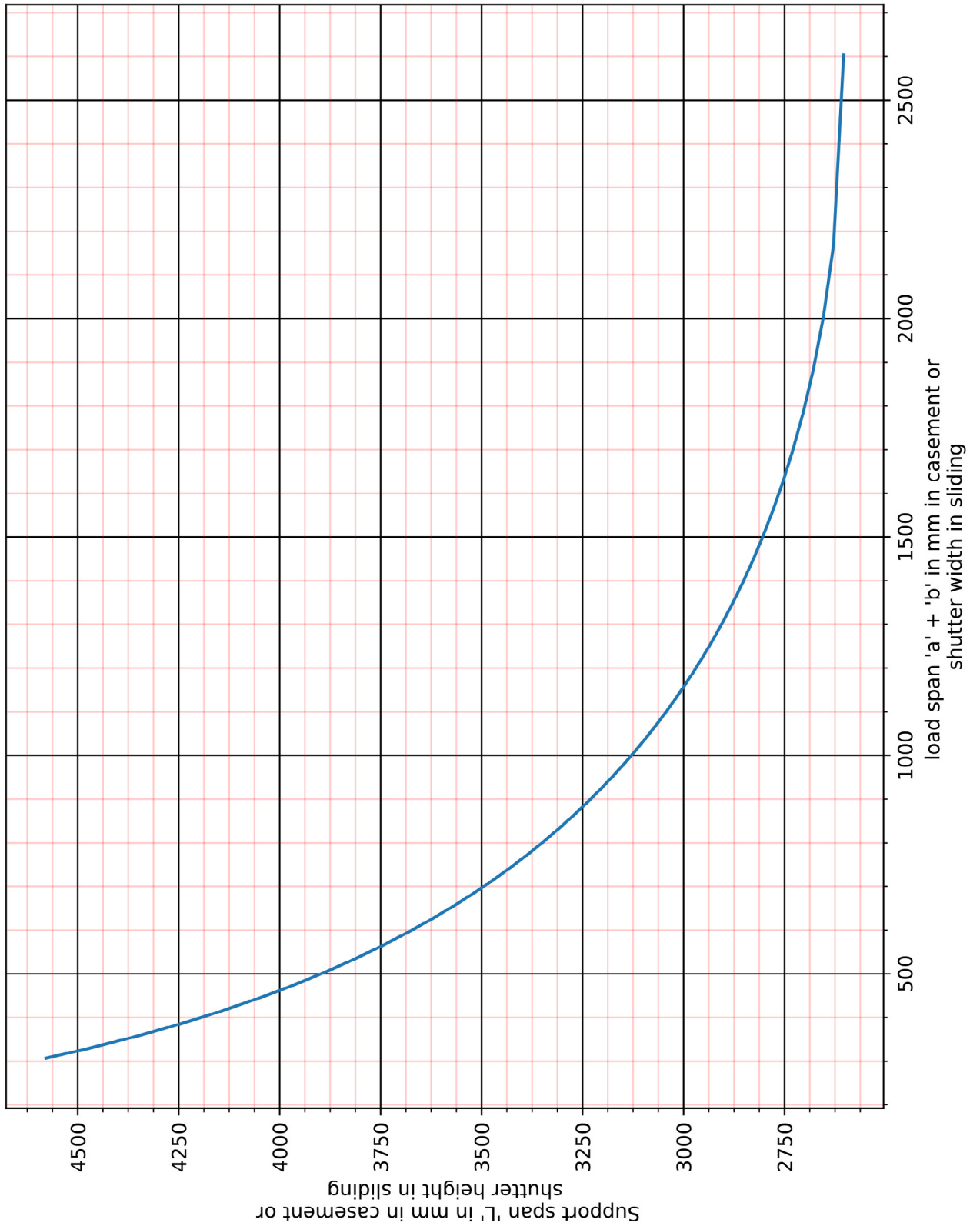

Size Selection Chart - CHART E - 2000 Pa
at 2000 Pa & EI = 236.17 x 10⁹ N-mm²

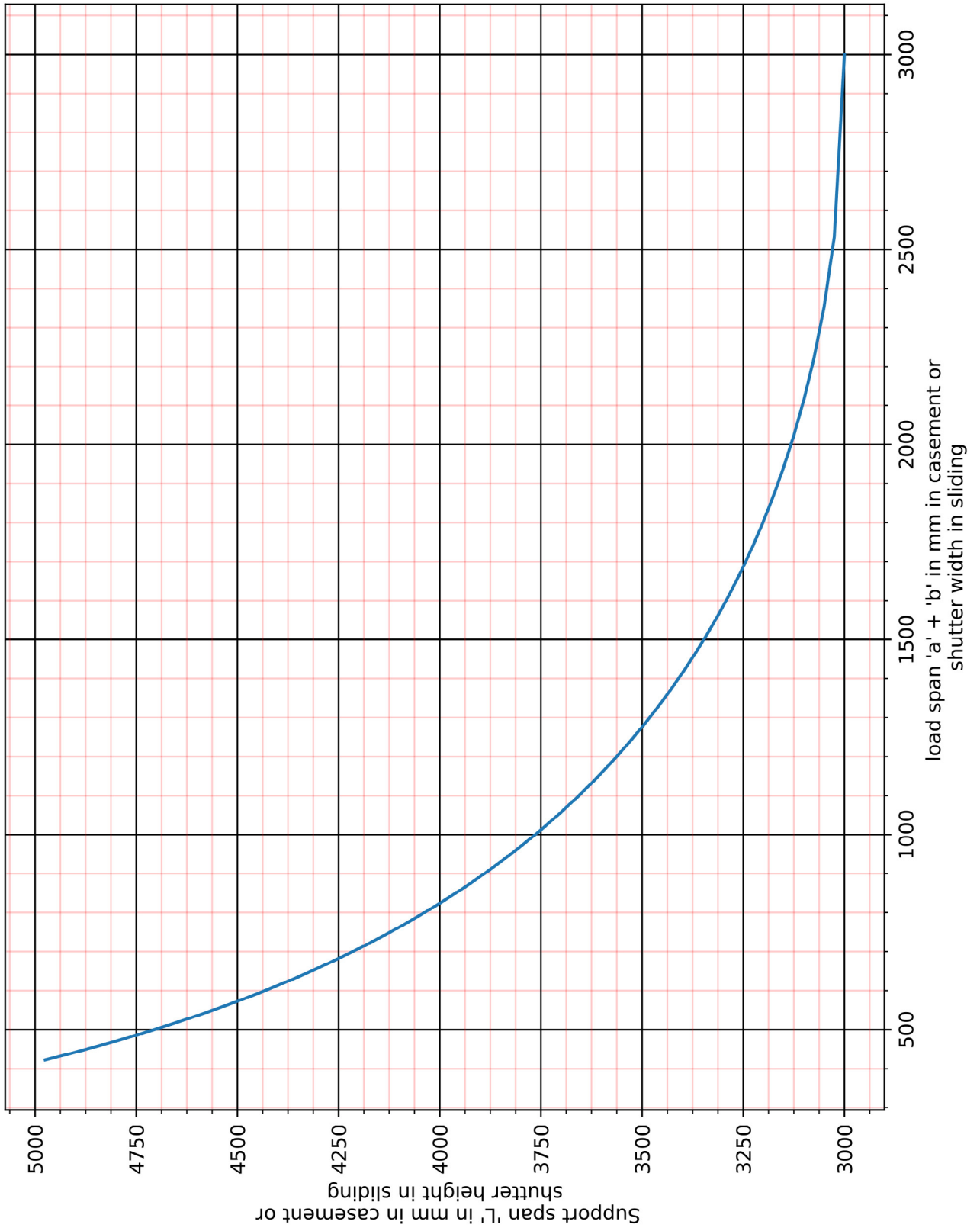

Size Selection Chart - CHART E - 1500 Pa
at 1500 Pa & EI = 236.17 x 10⁹ N-mm²

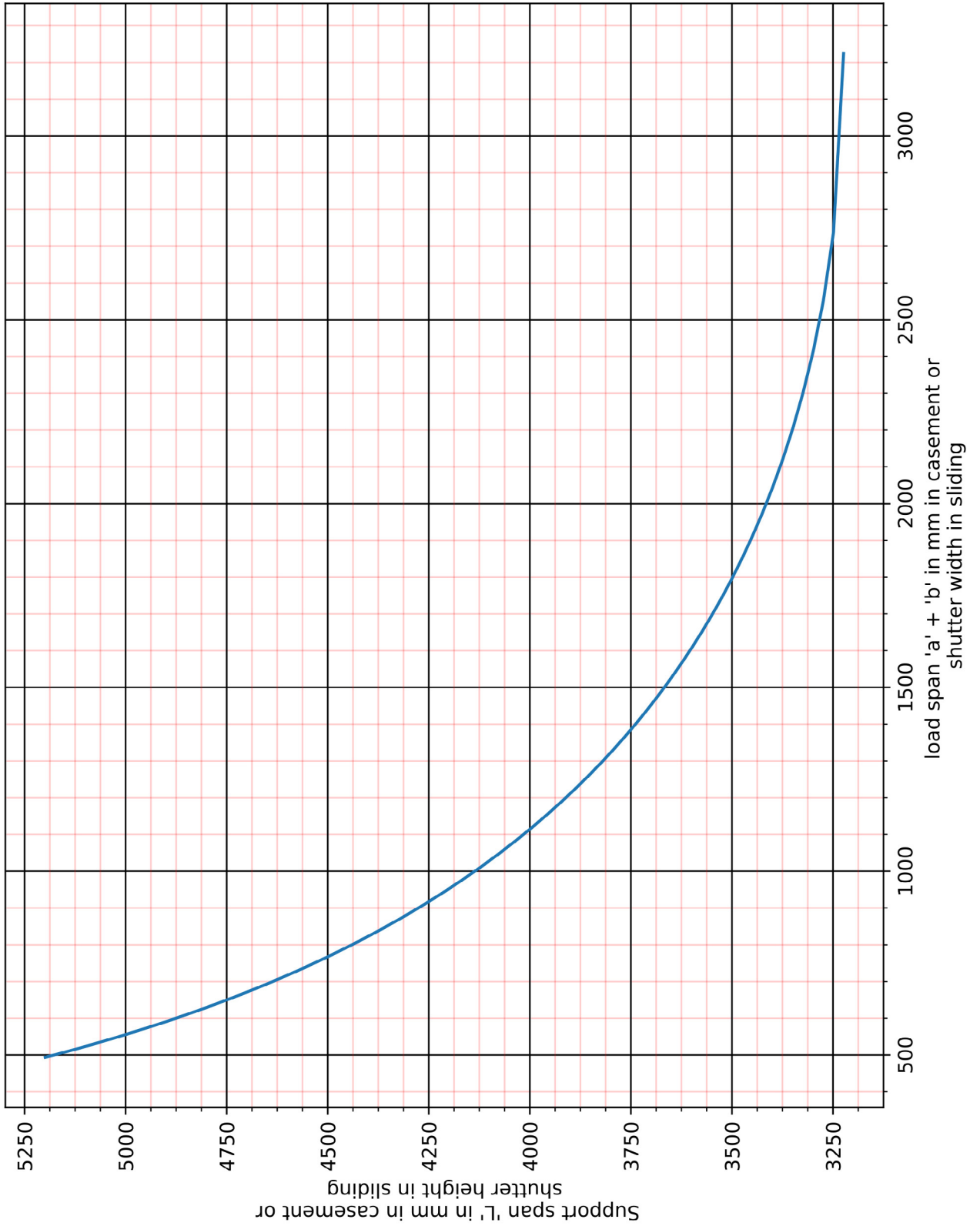

N MINIMAL SERIES

Size Selection Chart - CHART E - 3000 Pa
at 3000 Pa & EI = 236.17 x 10⁹ N-mm².

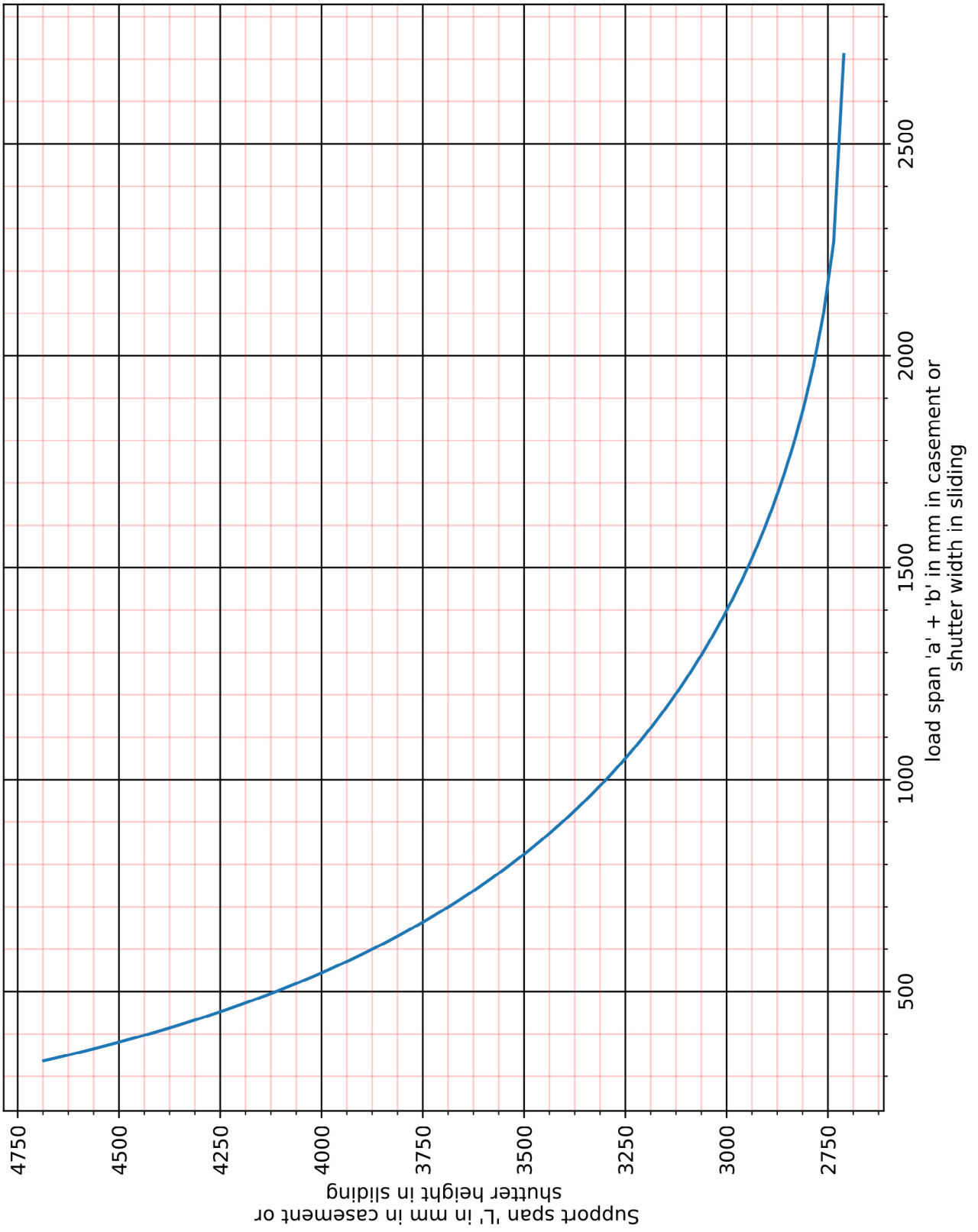

Size Selection Chart - CHART E - 2500 Pa
at 2500 Pa & EI = 236.17 x 10⁹ N-mm²

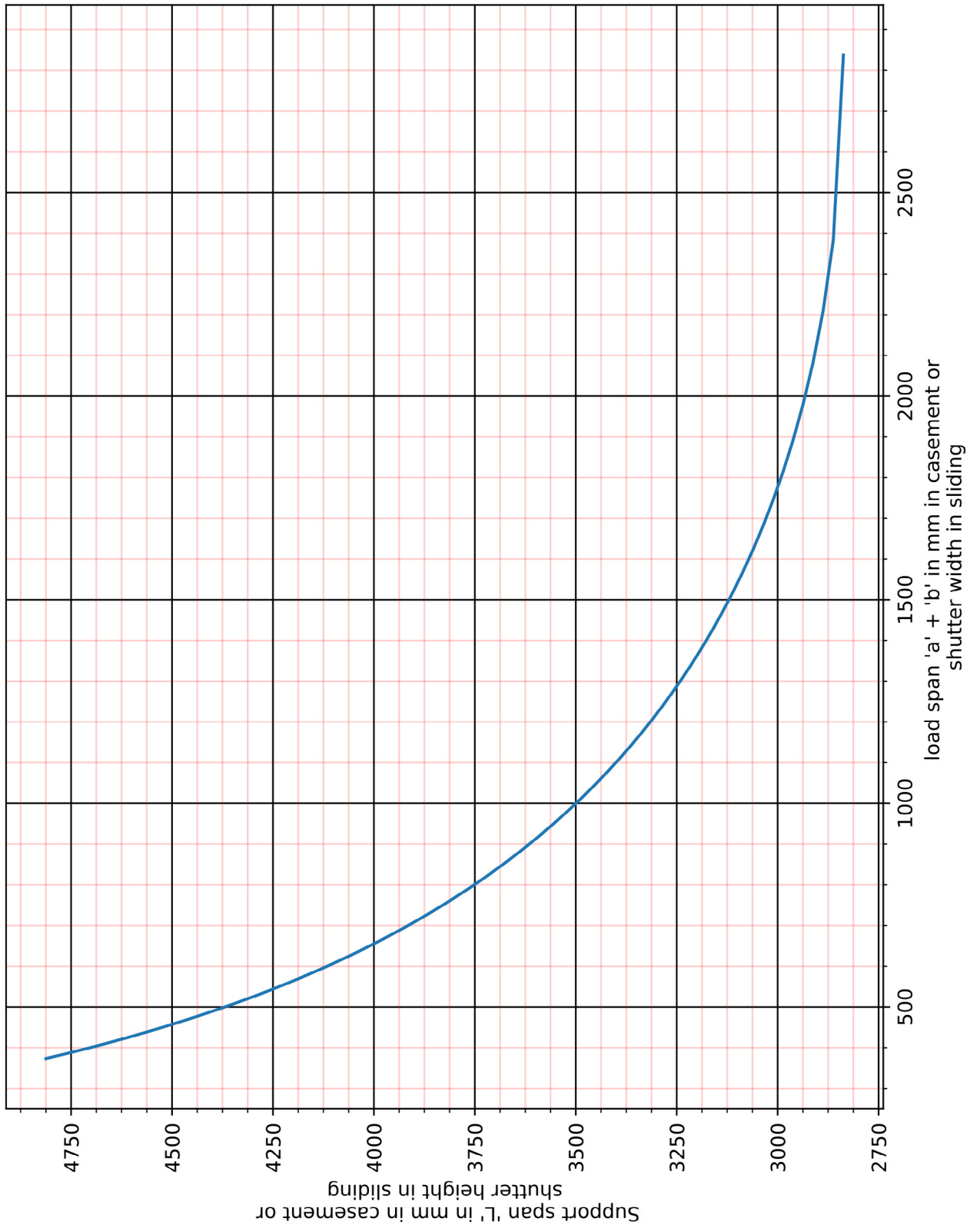

Size Selection Chart - GRAPH F - 1500 Pa
at 1500 Pa & EI = 271.41 x 10⁹ N-mm²

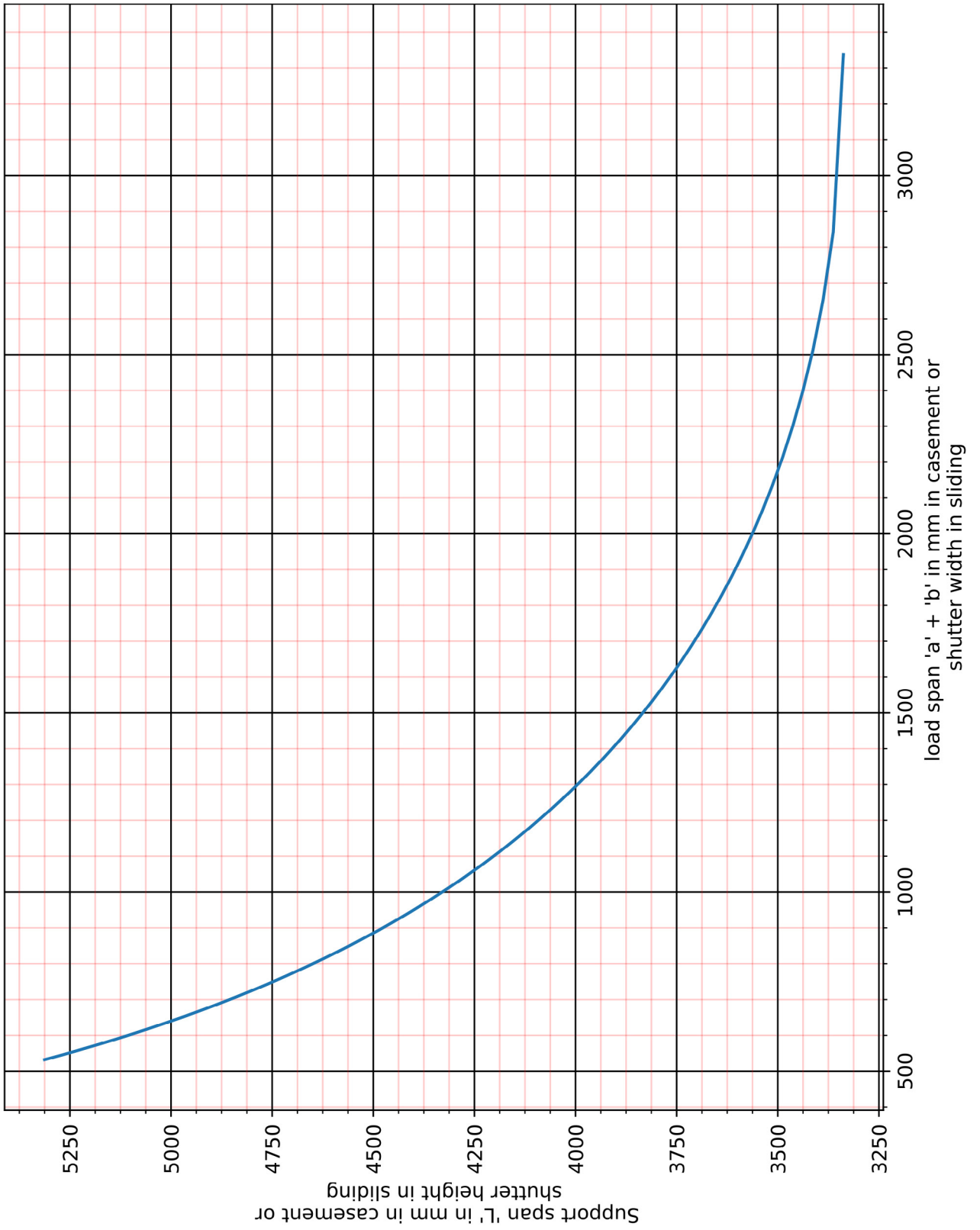

Size Selection Chart - CHART F - 1000 Pa
at 1000 Pa & EI = 271.41 x 10⁹ N-mm²

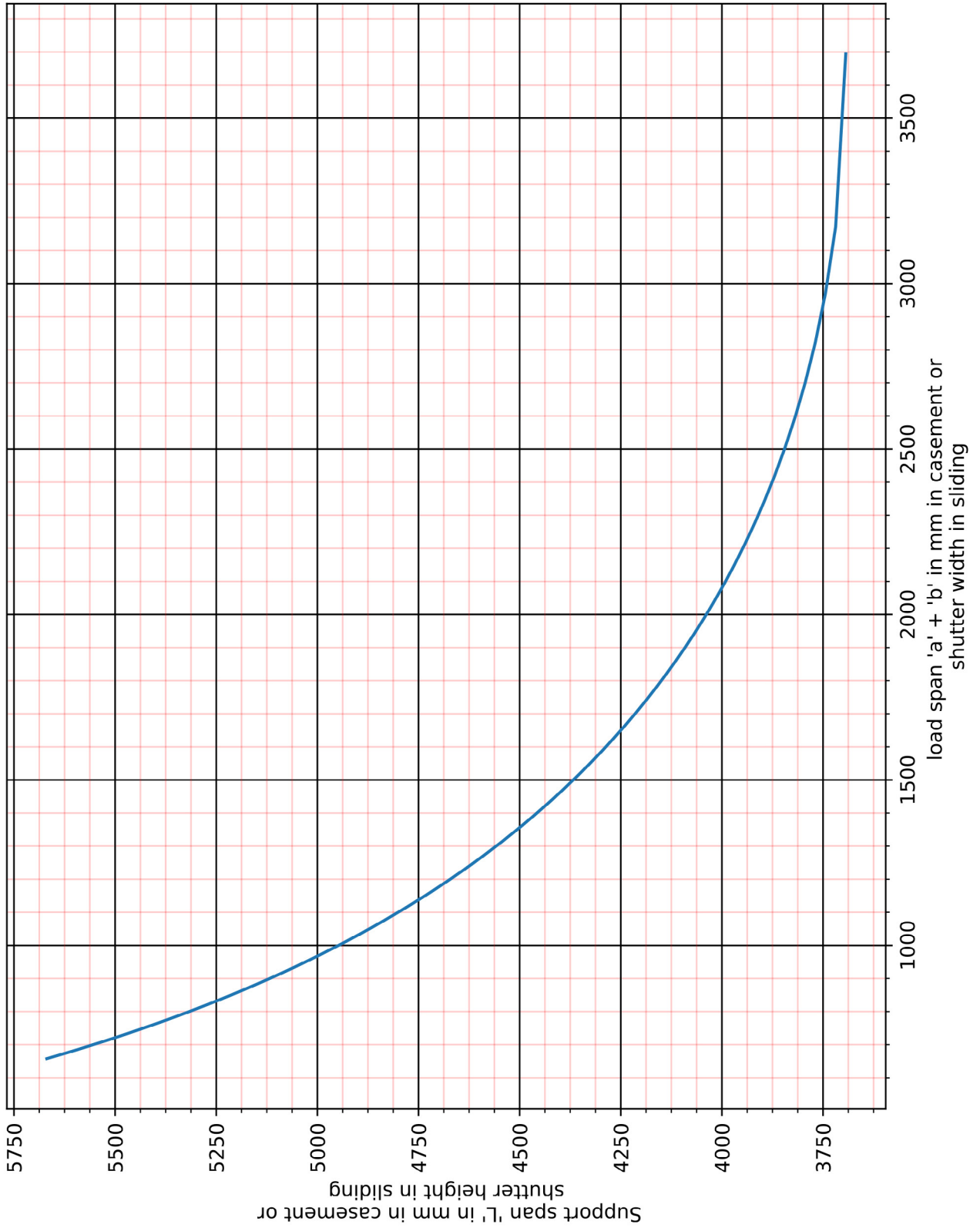

Size Selection Chart - CHART F - 2500 Pa
at 2500 Pa & EI = 271.41 x 10⁹ N-mm²

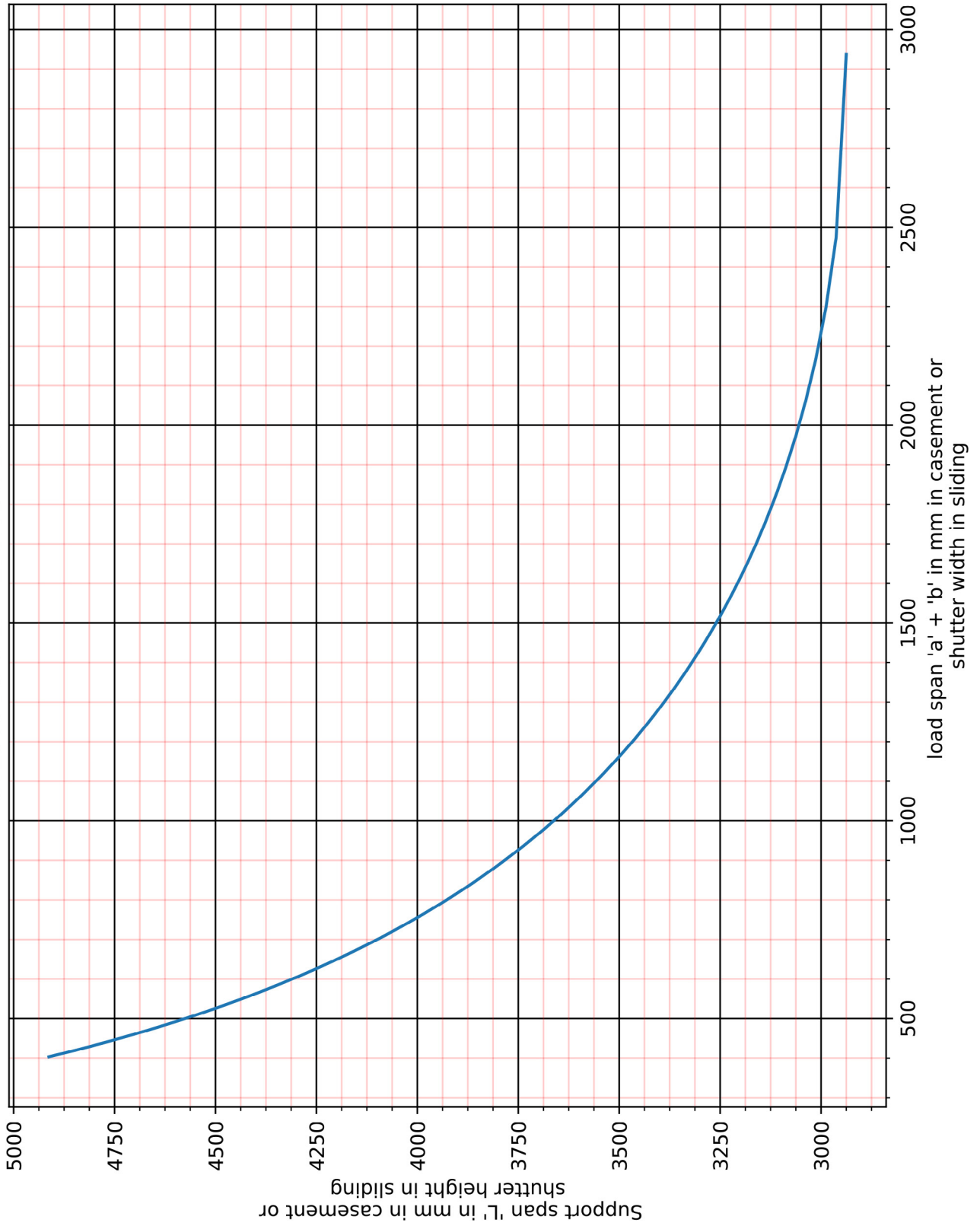

Size Selection Chart - CHART F - 2000 Pa
at 2000 Pa & EI = 271.41 x 10⁹ N-mm²

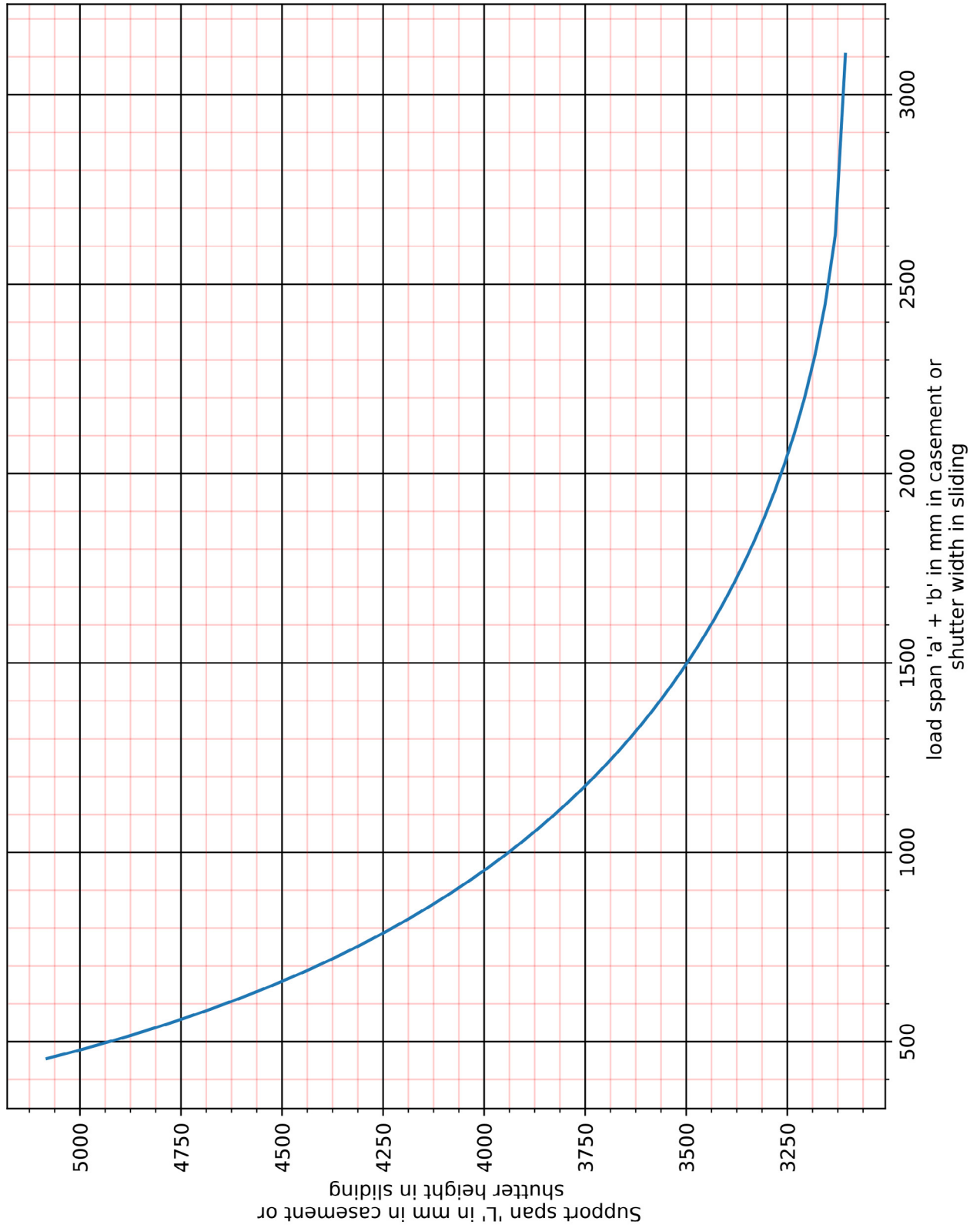

Size Selection Chart - CHART F - 3000 Pa
at 3000 Pa & EI = 271.41 x 10⁹ N-mm²

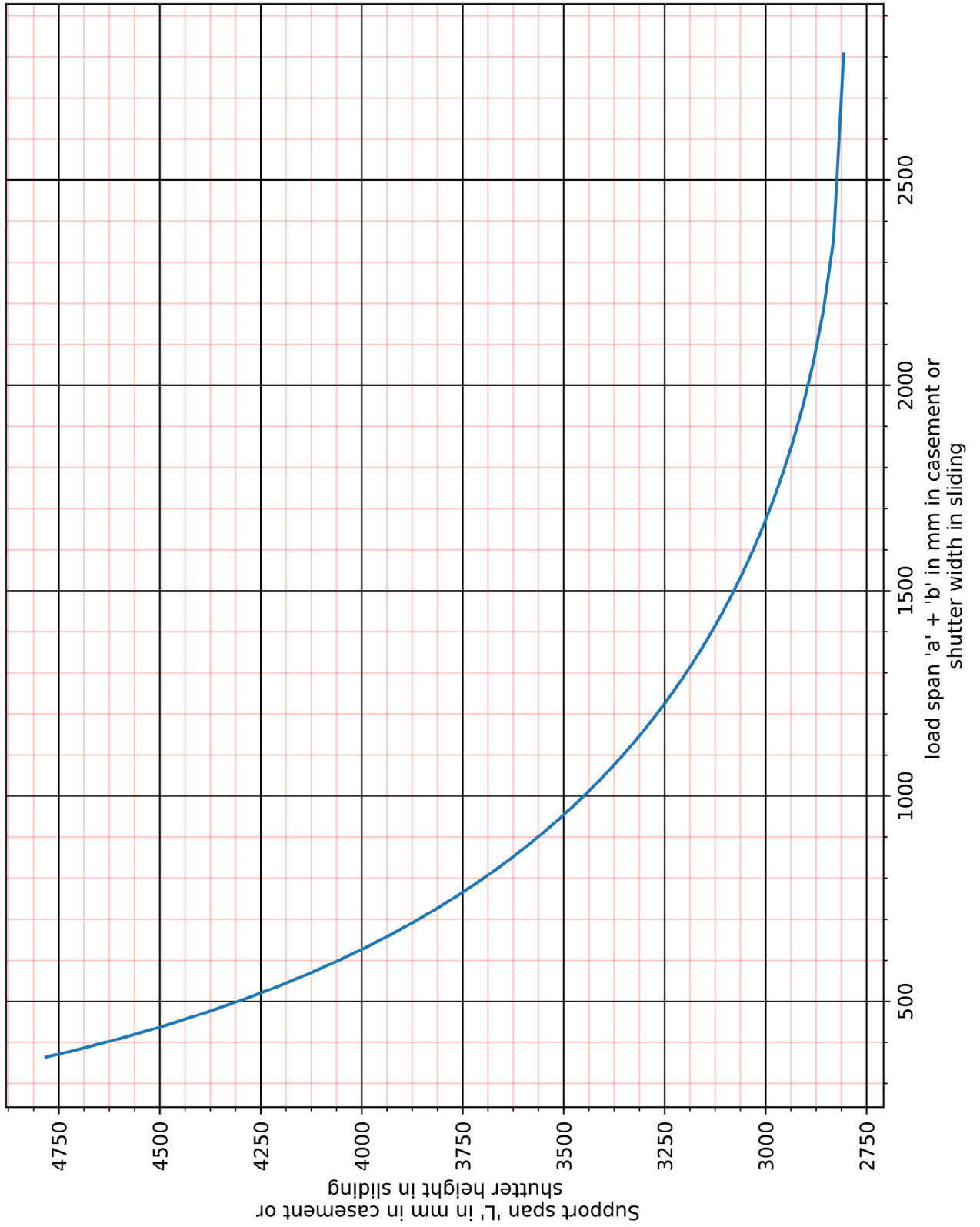

N MINIMAL SERIES

Size Selection Chart - CHART - A - 1000 Pa
at 1000 Pa & EI = 14.71 x 10⁹ N-mm²

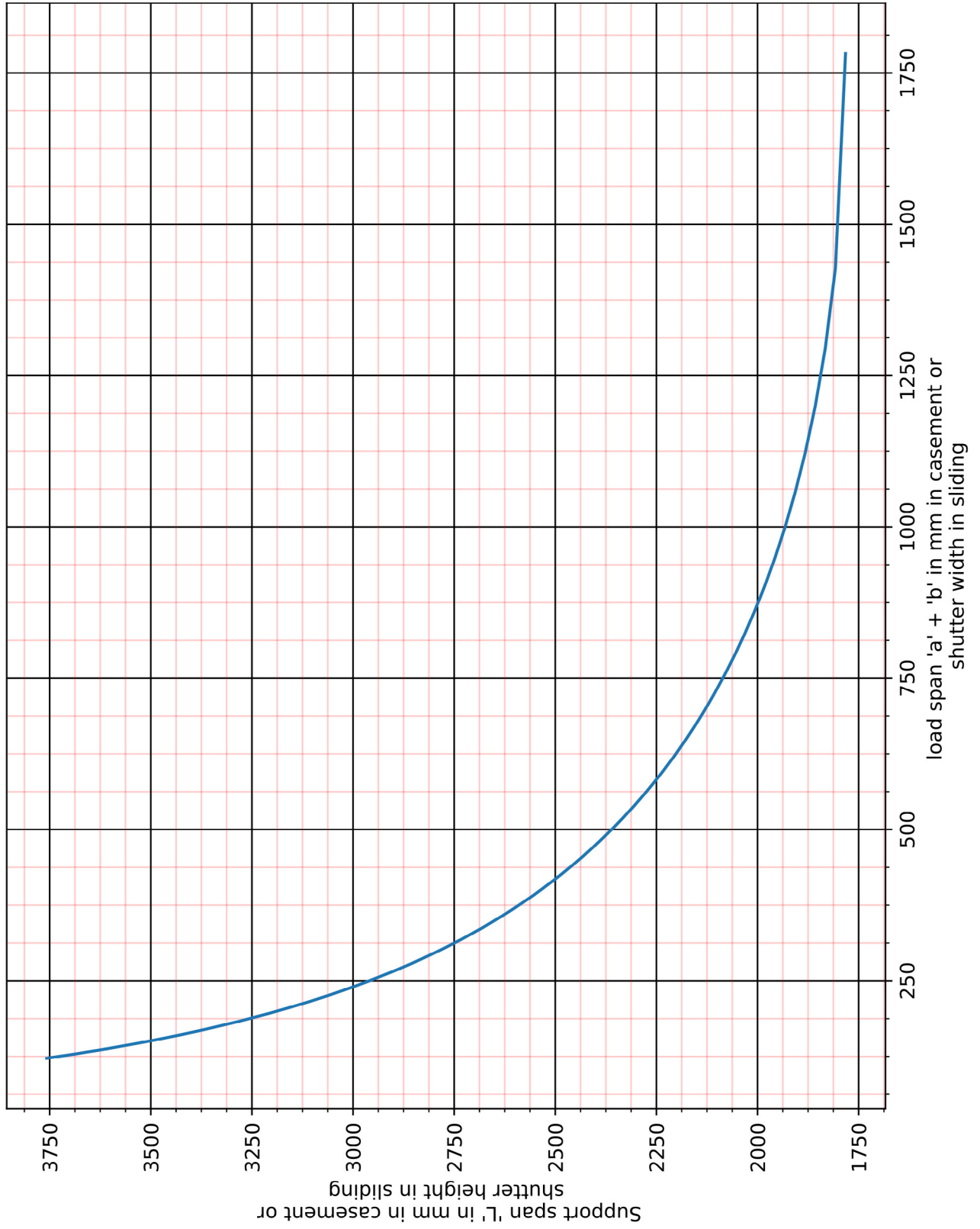

N MINIMAL SERIES

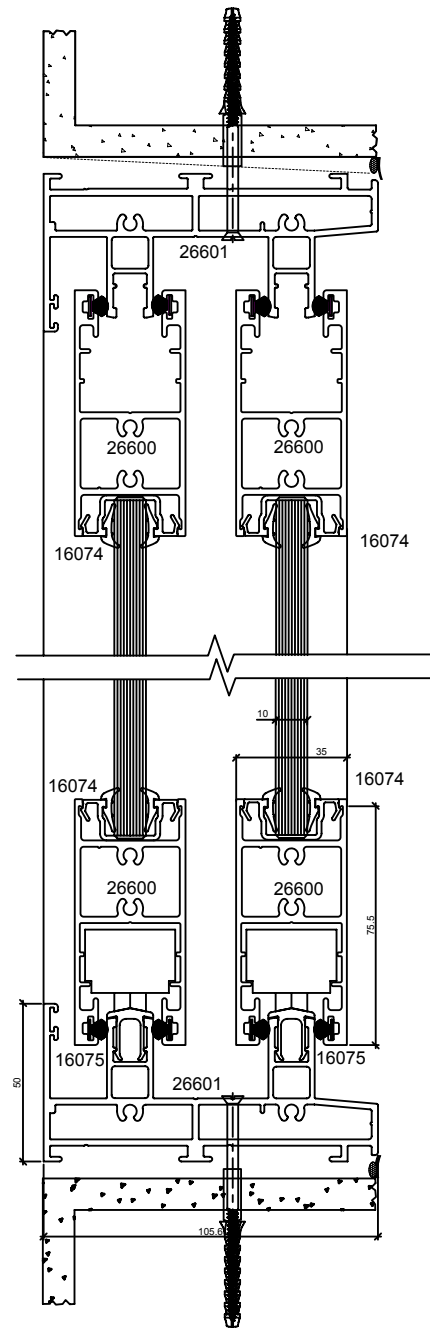
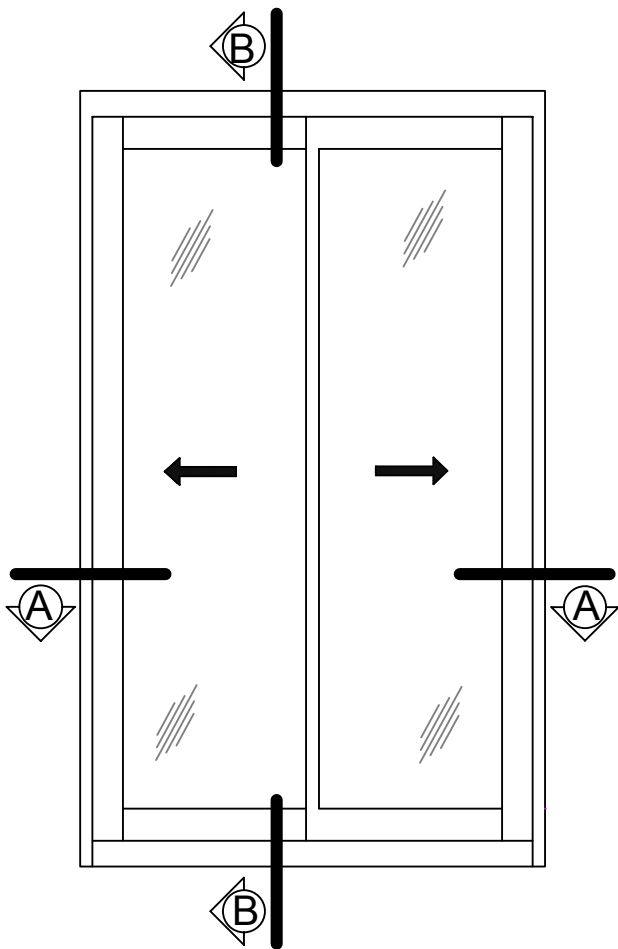

DETAIL SECTION - 'BB'

PROFILES		
Description	Shape	Section No.
Frame side		26604
Frame Bottom		26601
Bottom Sash		26600
Side Sash		26599
Interlock		26606
Interlock		26607
Adaptor		16074
Adaptor		16075

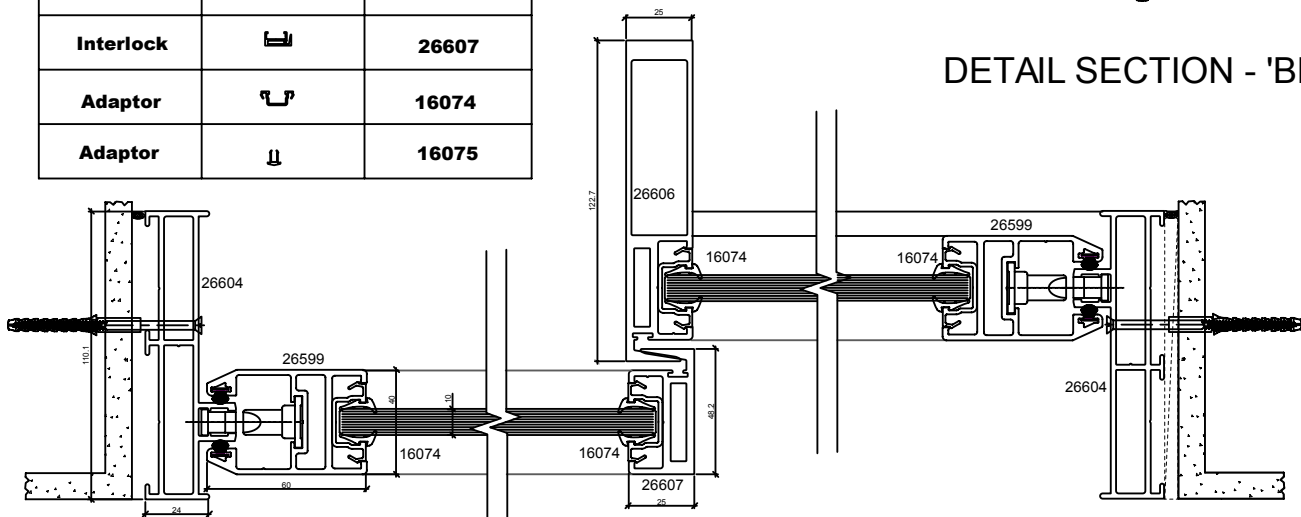

DETAIL SECTION - 'AA'

N MINIMAL SERIES

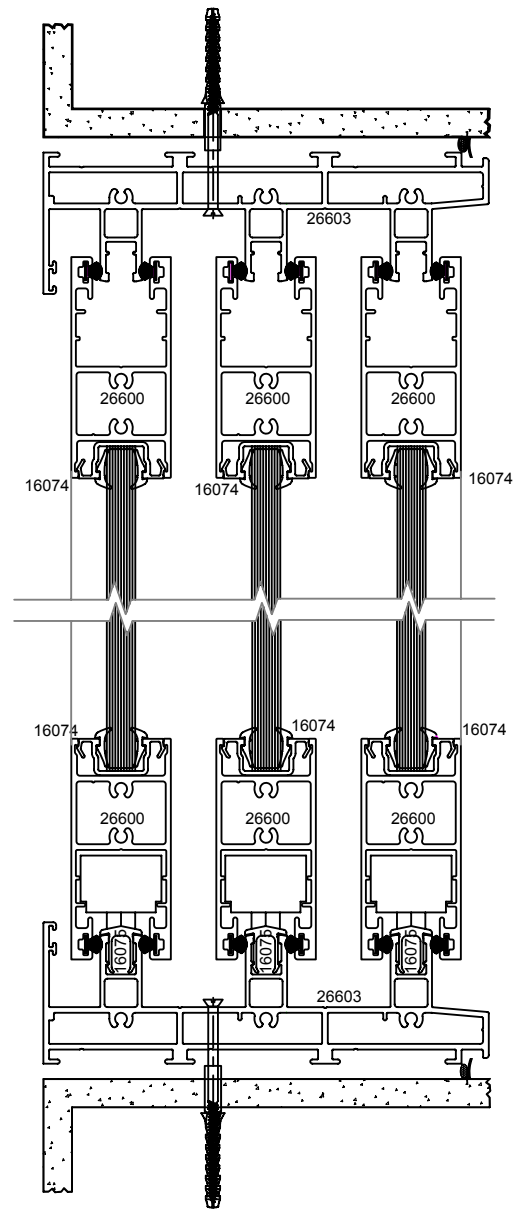
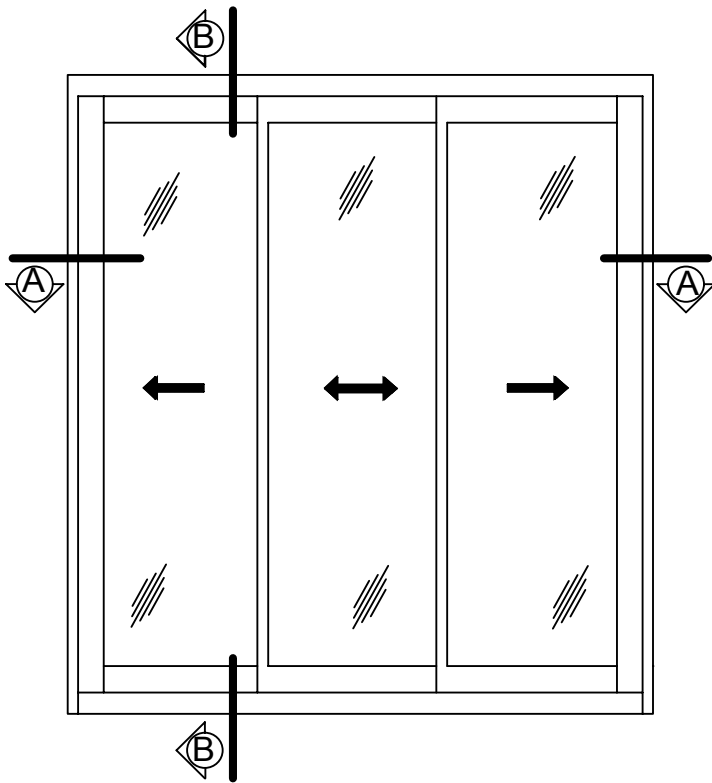

DETAIL SECTION - 'BB'

PROFILES		
Description	Shape	Section No.
Frame side		26602
Frame Bottom		26603
Bottom Sash		26600
Side Sash		26599
Interlock		26606
Interlock		26607
Adaptor		16074
Adaptor		16075

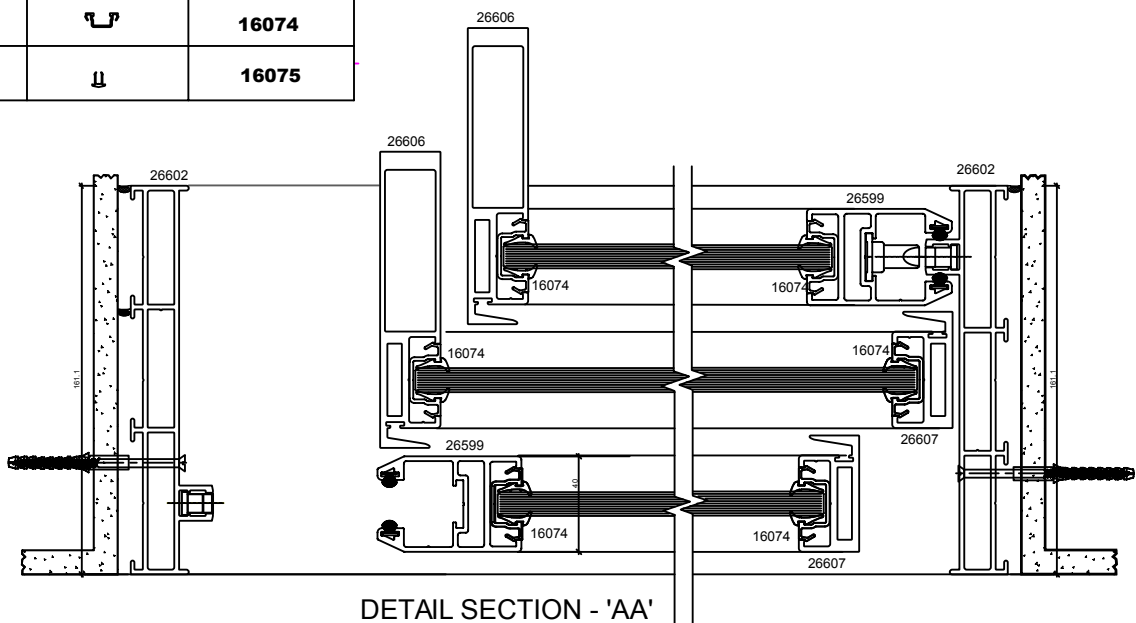

DETAIL SECTION - 'AA'

N MINIMAL SERIES

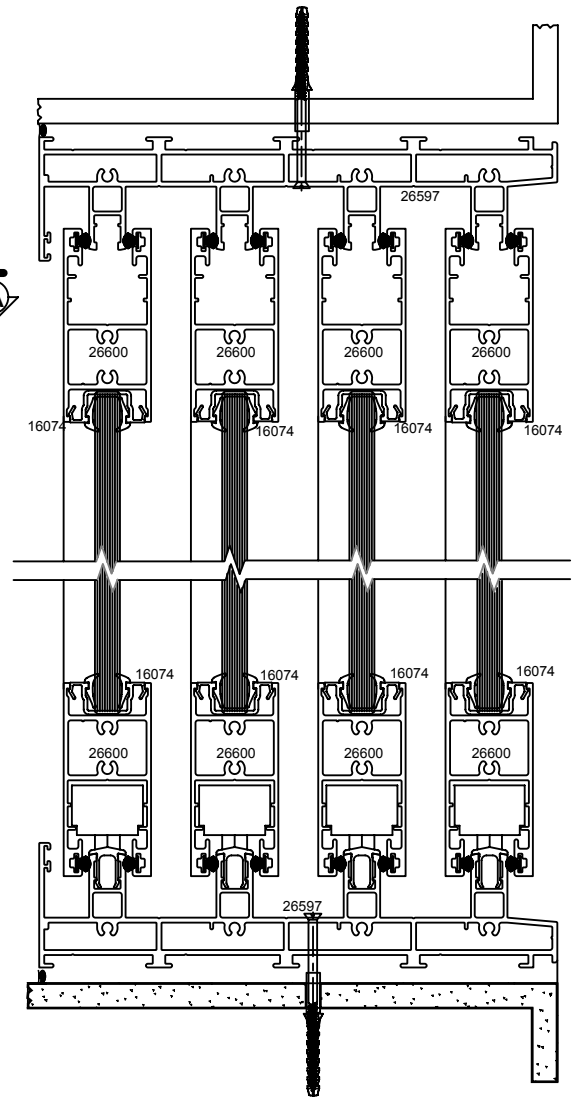
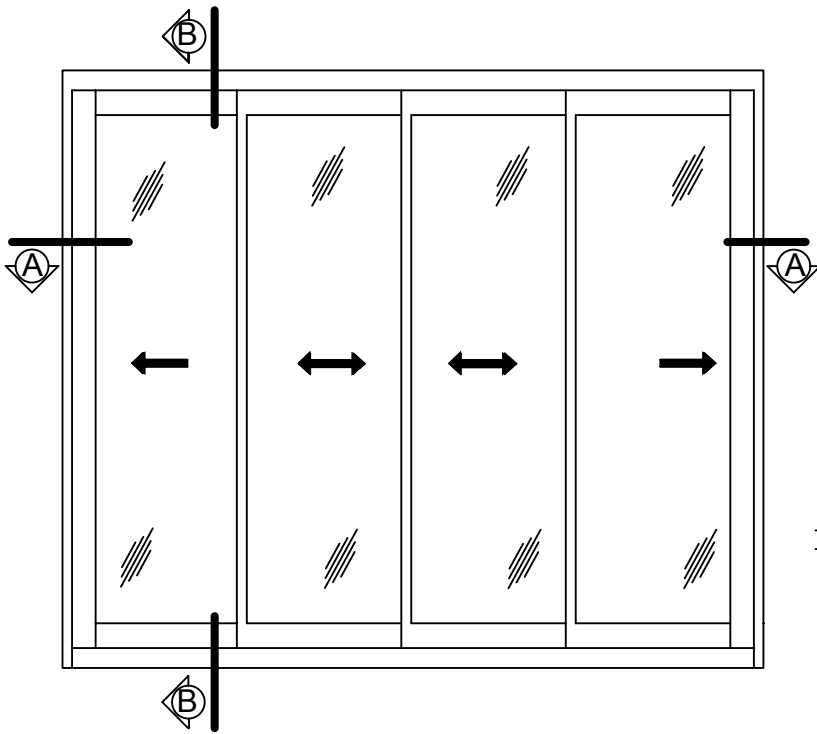

DETAIL SECTION - 'BB'

PROFILES		
Description	Shape	Section No.
Frame side		26598
Frame Bottom		26597
Bottom Sash		26600
Side Sash		26599
Interlock		26606
Interlock		26607
Adaptor		16074
Adaptor		16075

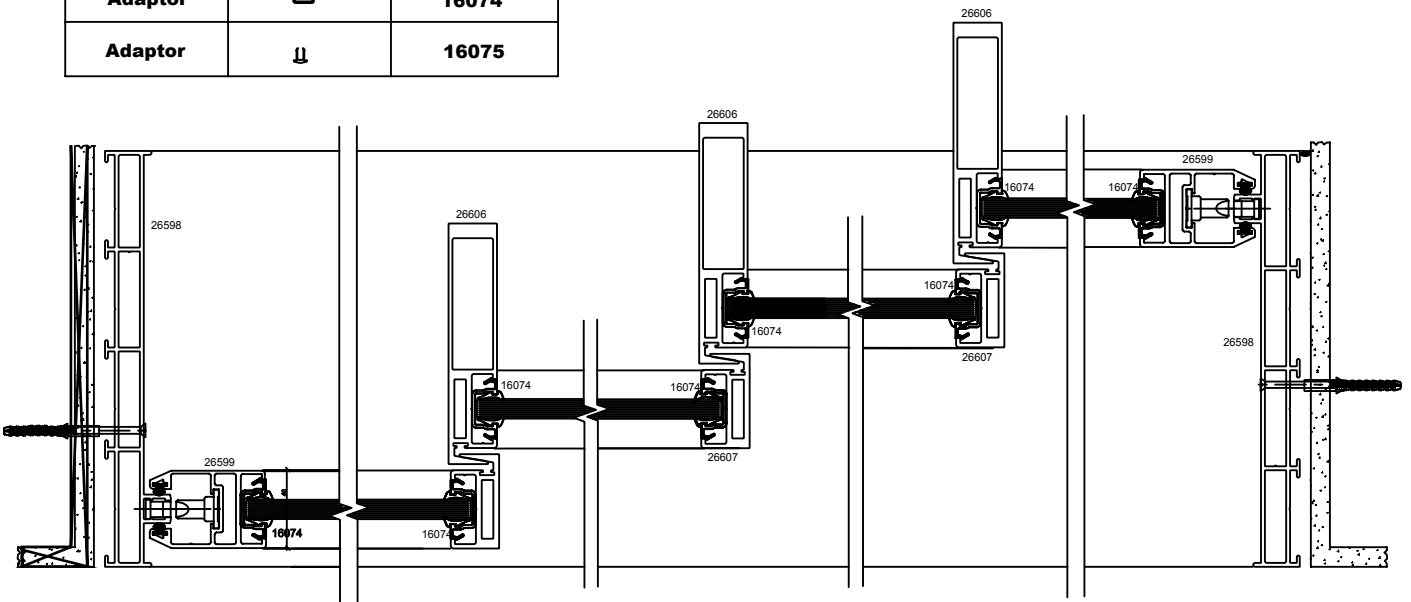

DETAIL SECTION - 'AA'

N MINIMAL SERIES

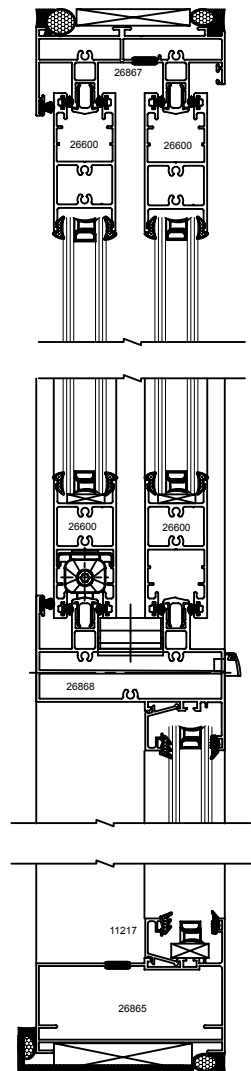
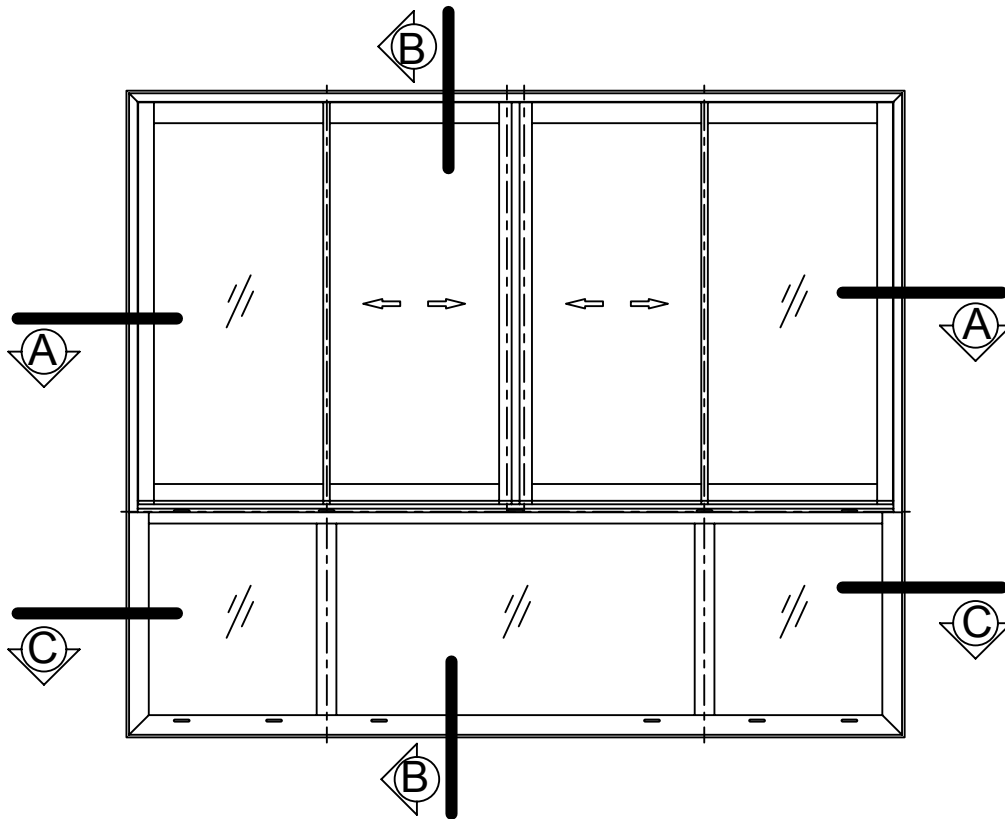

DETAIL SECTION - 'BB'

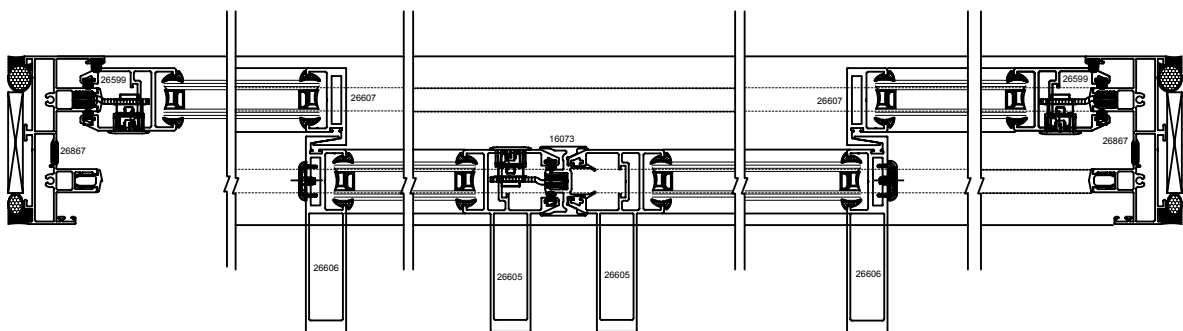

DETAIL SECTION - 'AA'

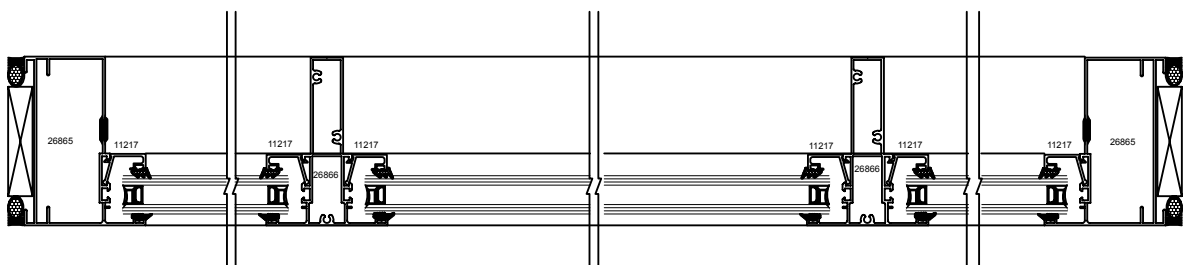

DETAIL SECTION - 'CC'

N MINIMAL SERIES

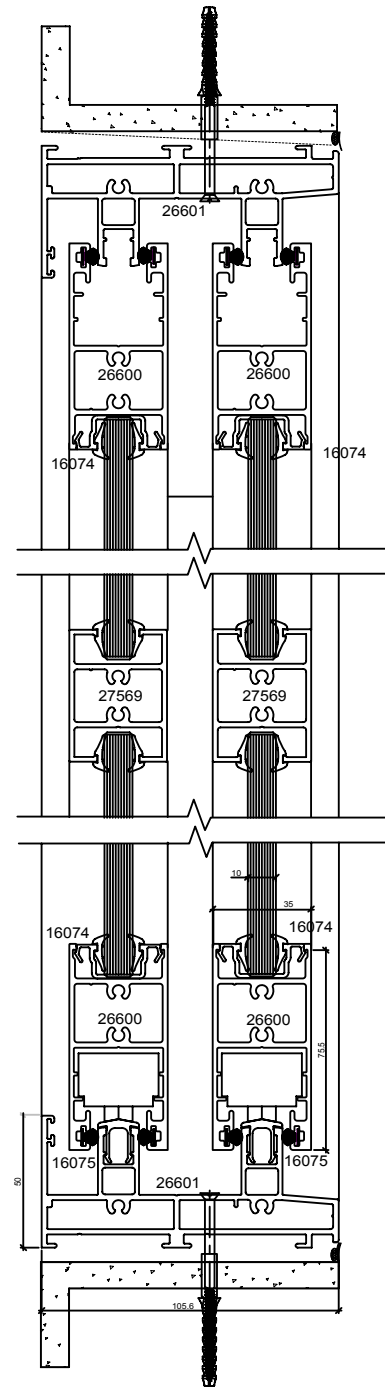
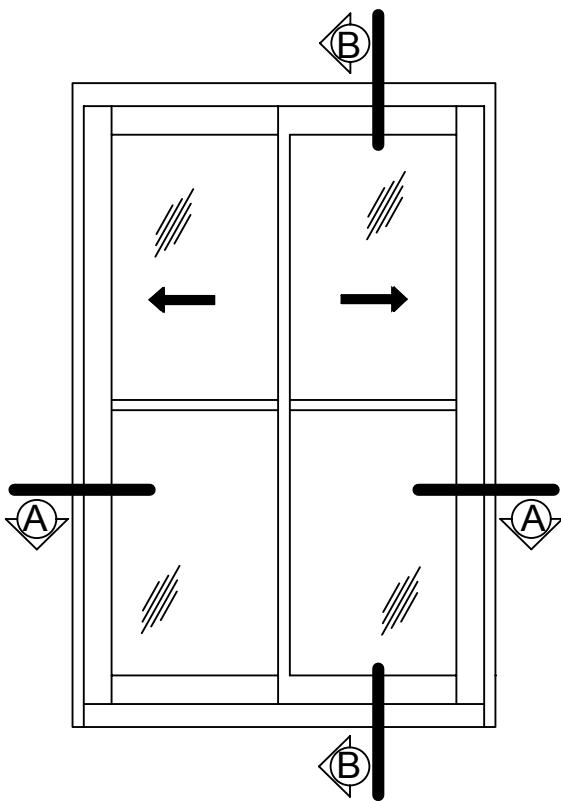

DETAIL SECTION - 'BB'

PROFILES		
Description	Shape	Section No.
Frame side		26604
Frame Bottom		26601
Bottom Sash		26600
Side Sash		26599
Interlock		26606
Interlock		26607
Adaptor		16074
Adaptor		16075
Middle Sash		27569

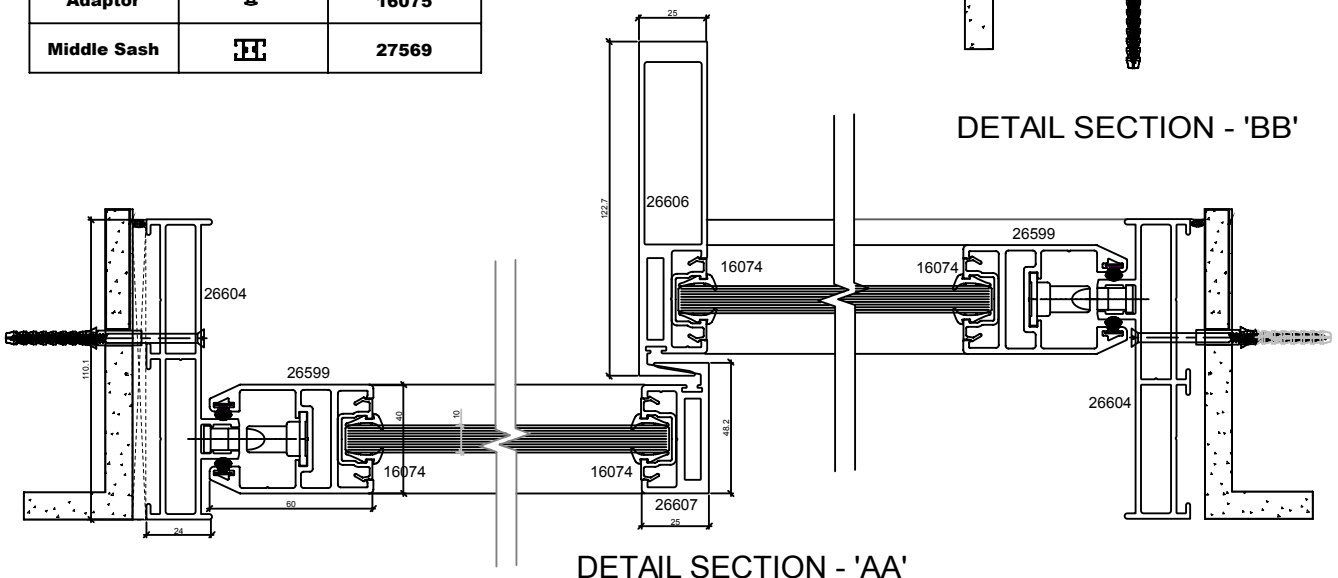

DETAIL SECTION - 'AA'

N MINIMAL SERIES

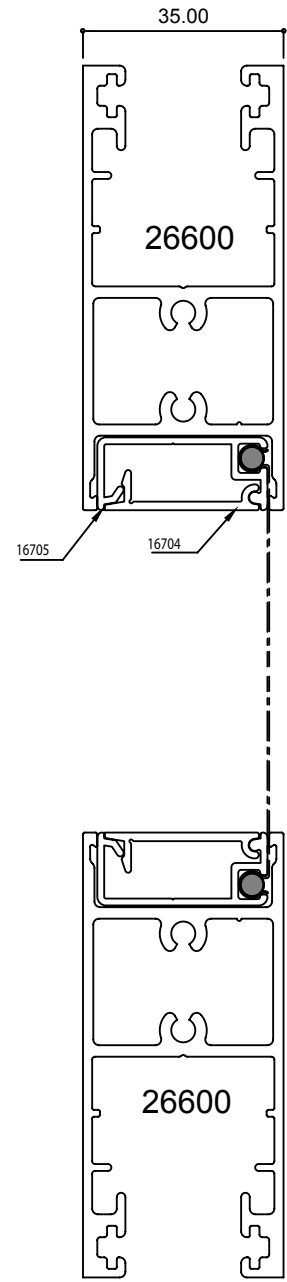
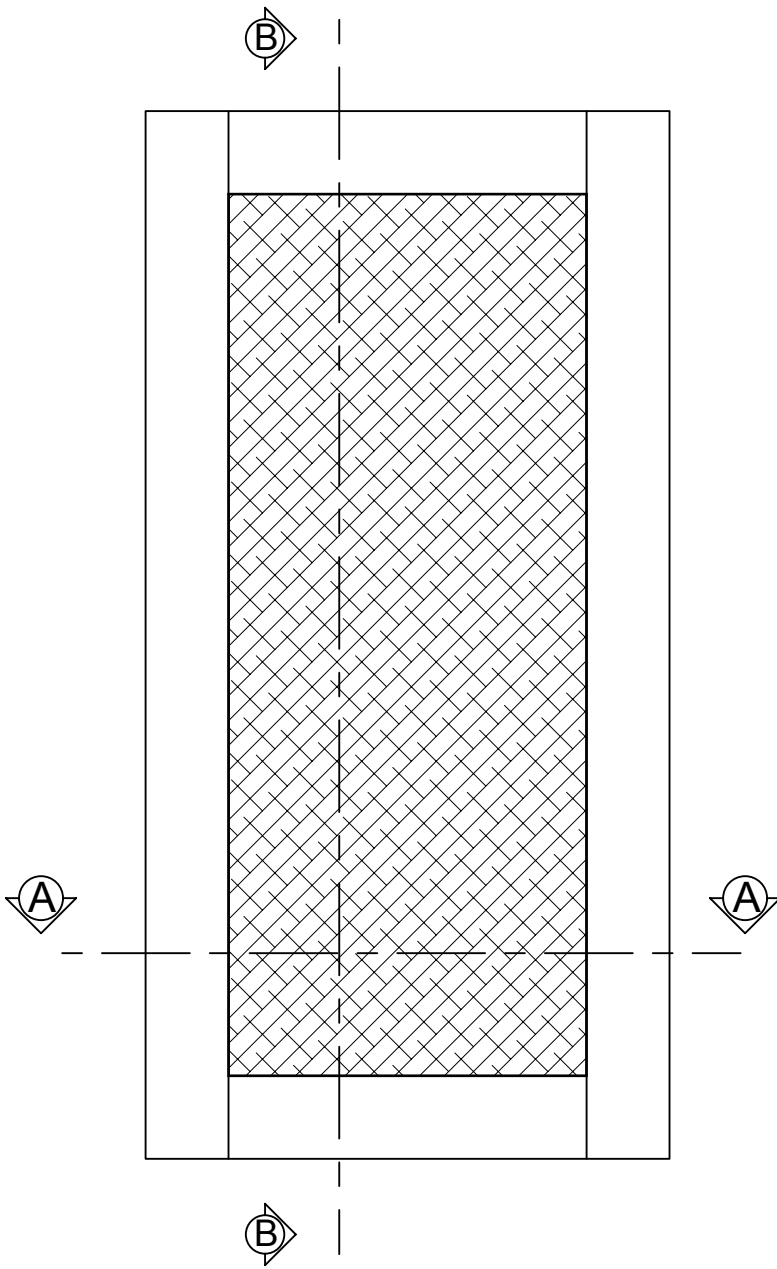

DETAIL SECTION - 'BB'



DETAIL SECTION - 'AA'

SLIDING WINDOW JUNCTION DETAIL

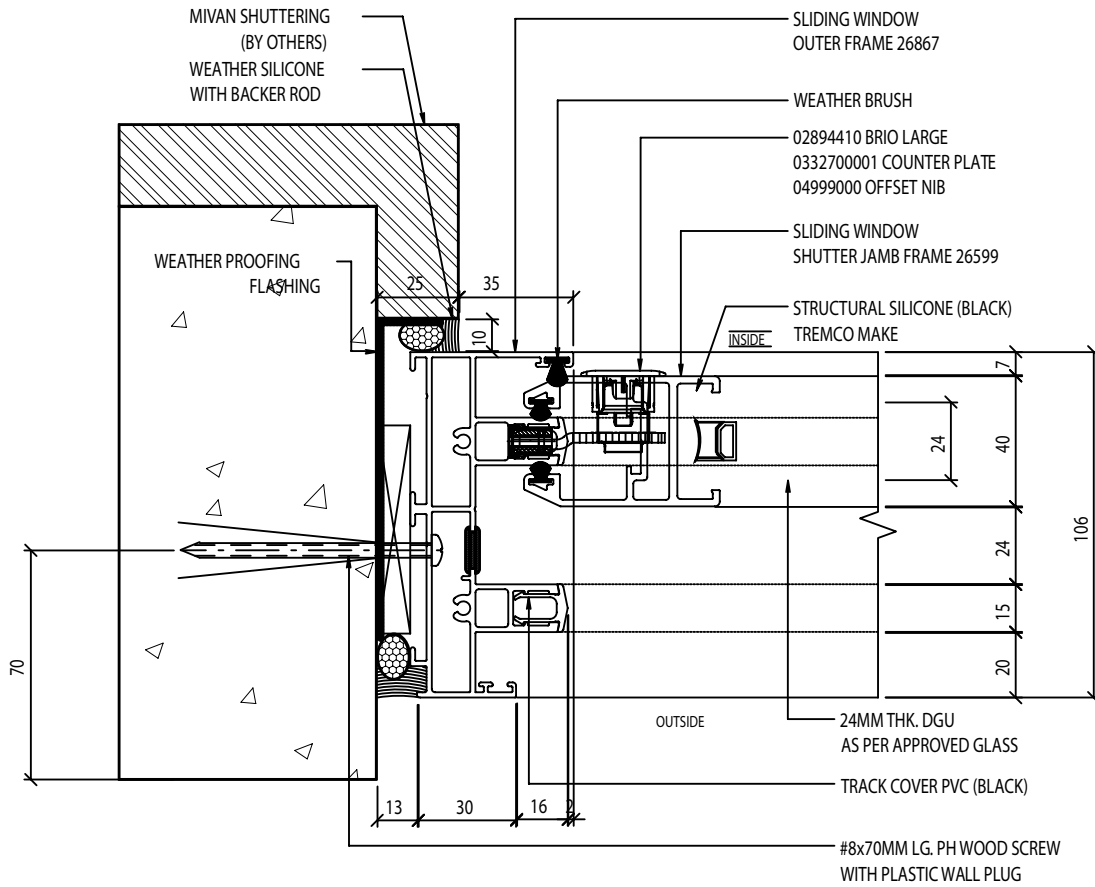

SLIDING WINDOW INTERLOCK DETAIL

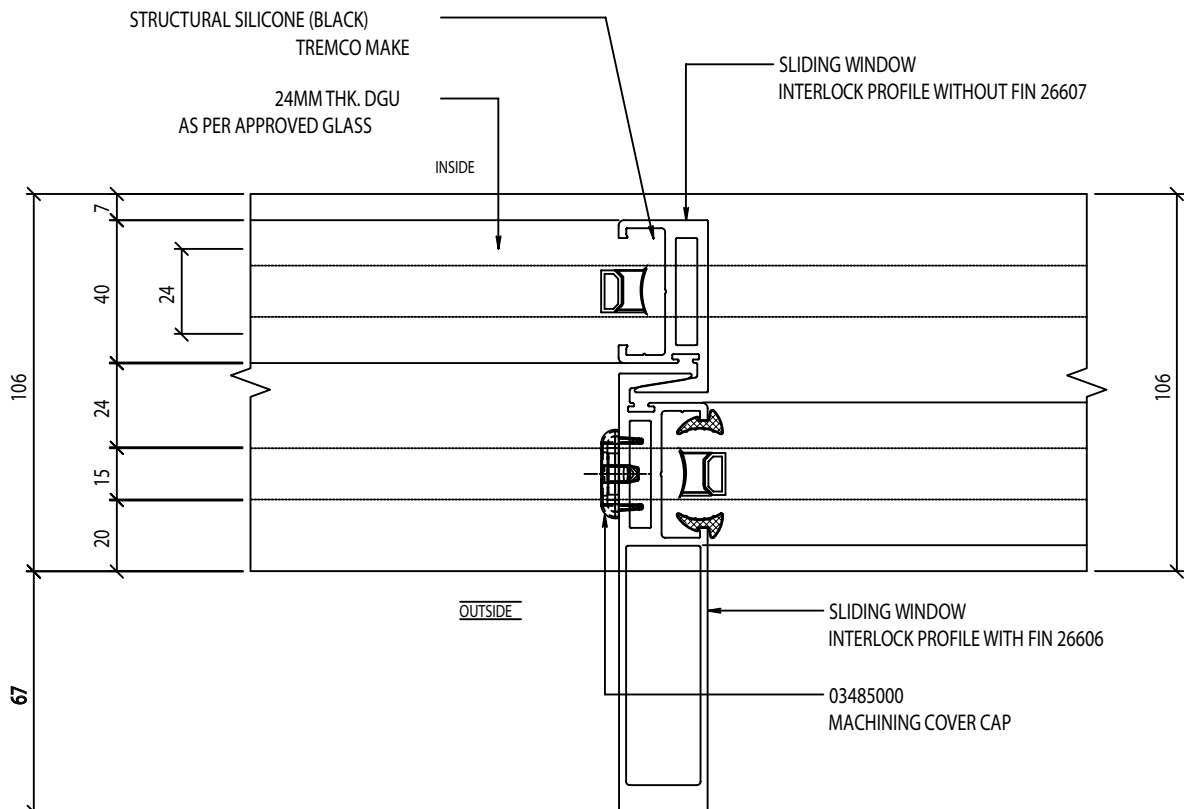

SLIDING WINDOW JUNCTION DETAIL

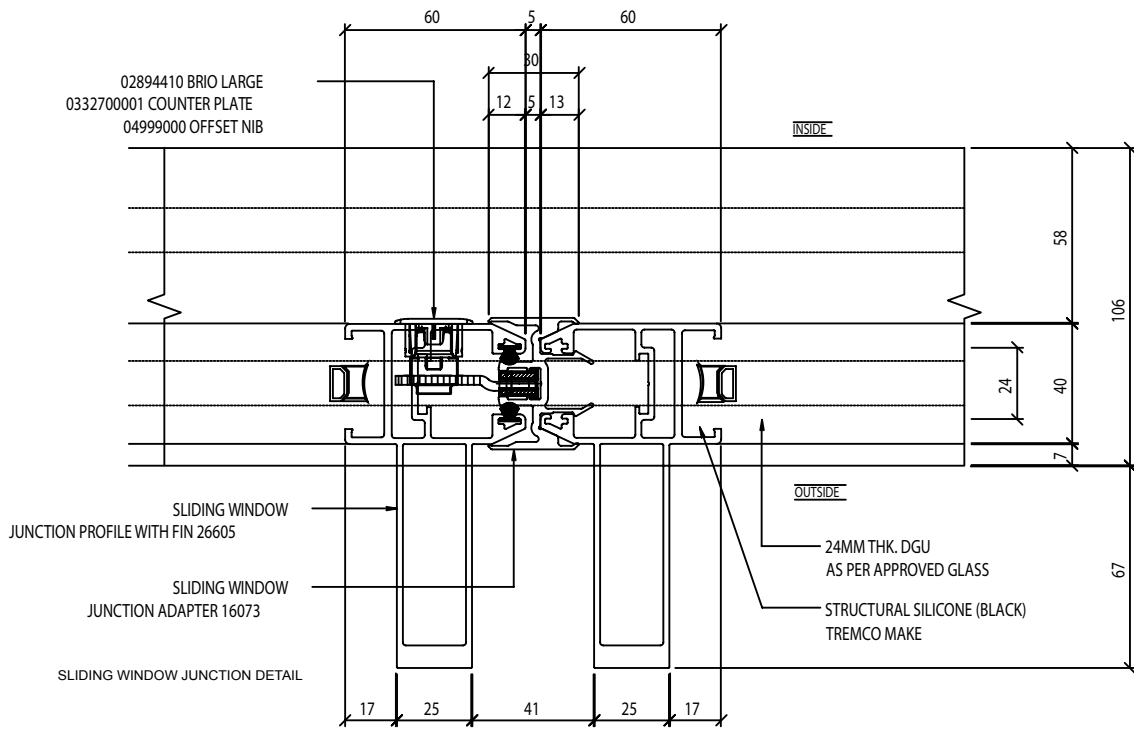

SLIDING WINDOW HEAD DETAIL

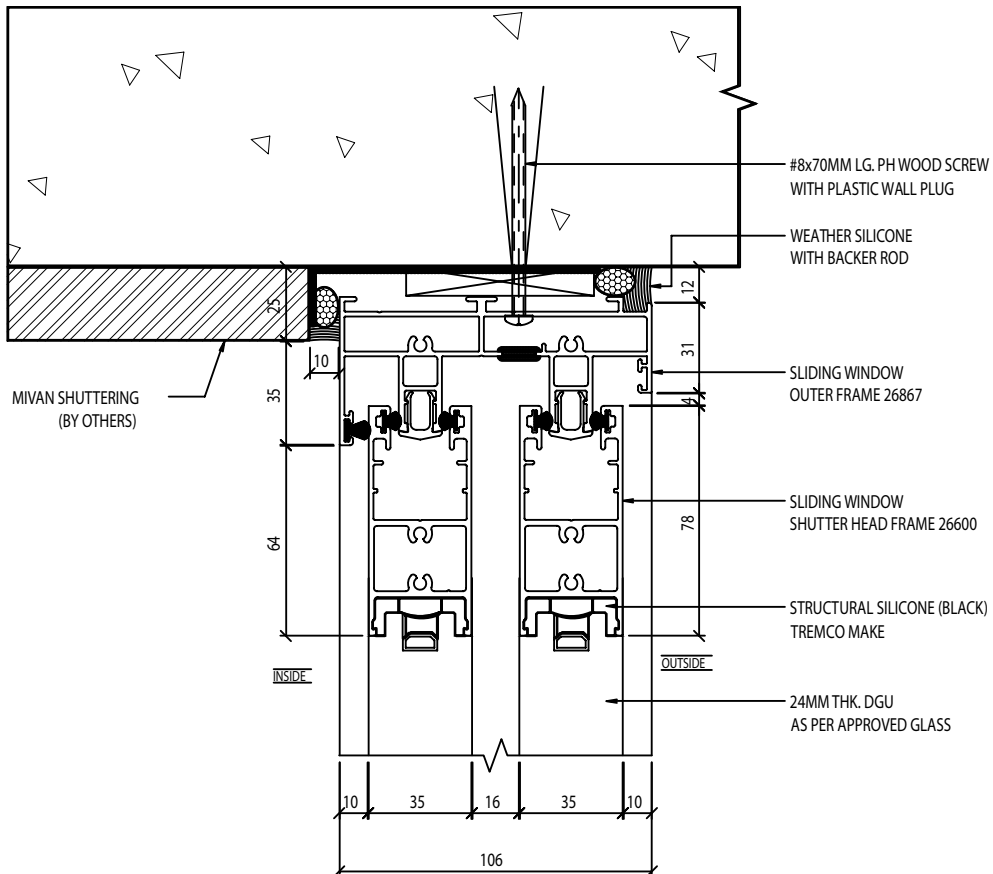

SLIDING WINDOW INTERMEDIATE DETAIL WITH BOTTOM PANEL

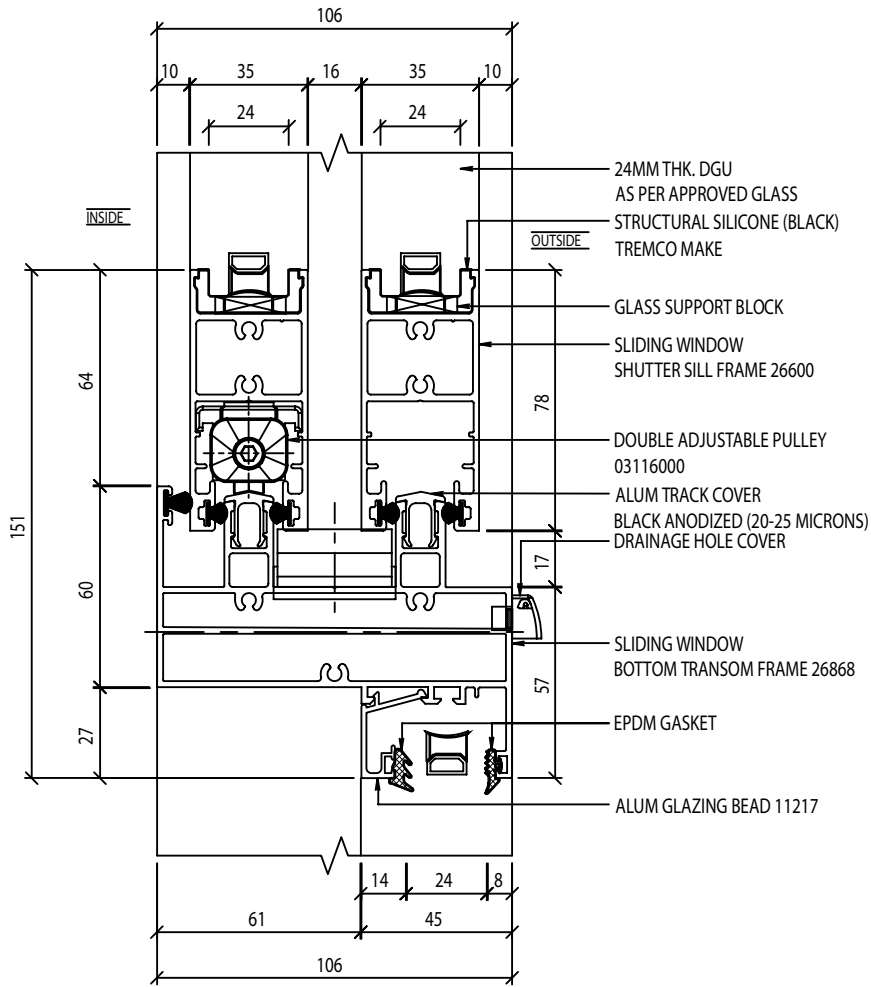

FIX PANEL JAMB DETAIL

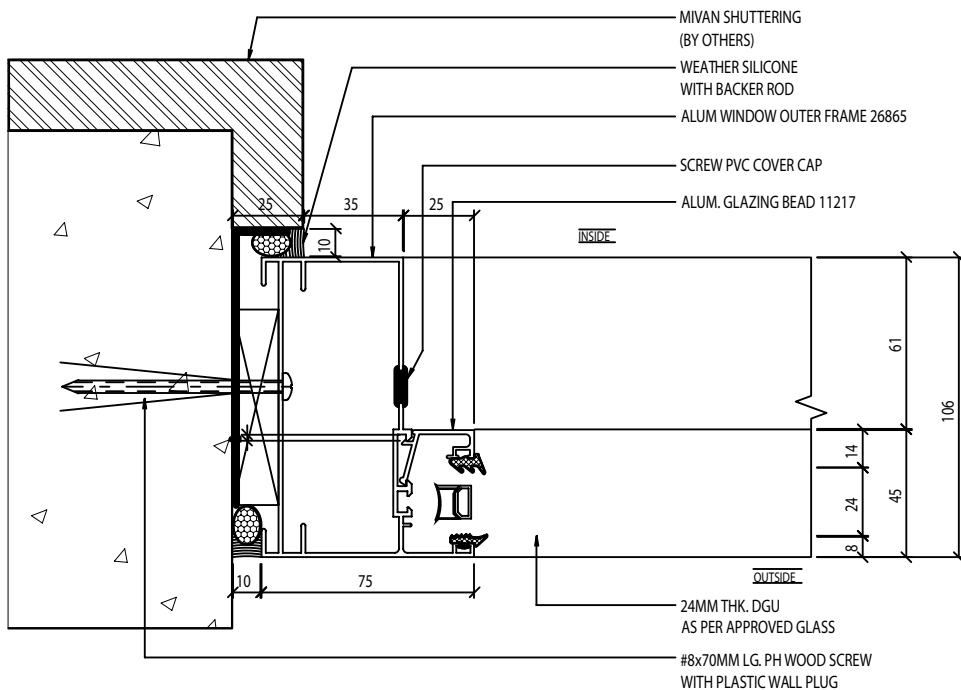

FIX PANEL SILL DETAIL

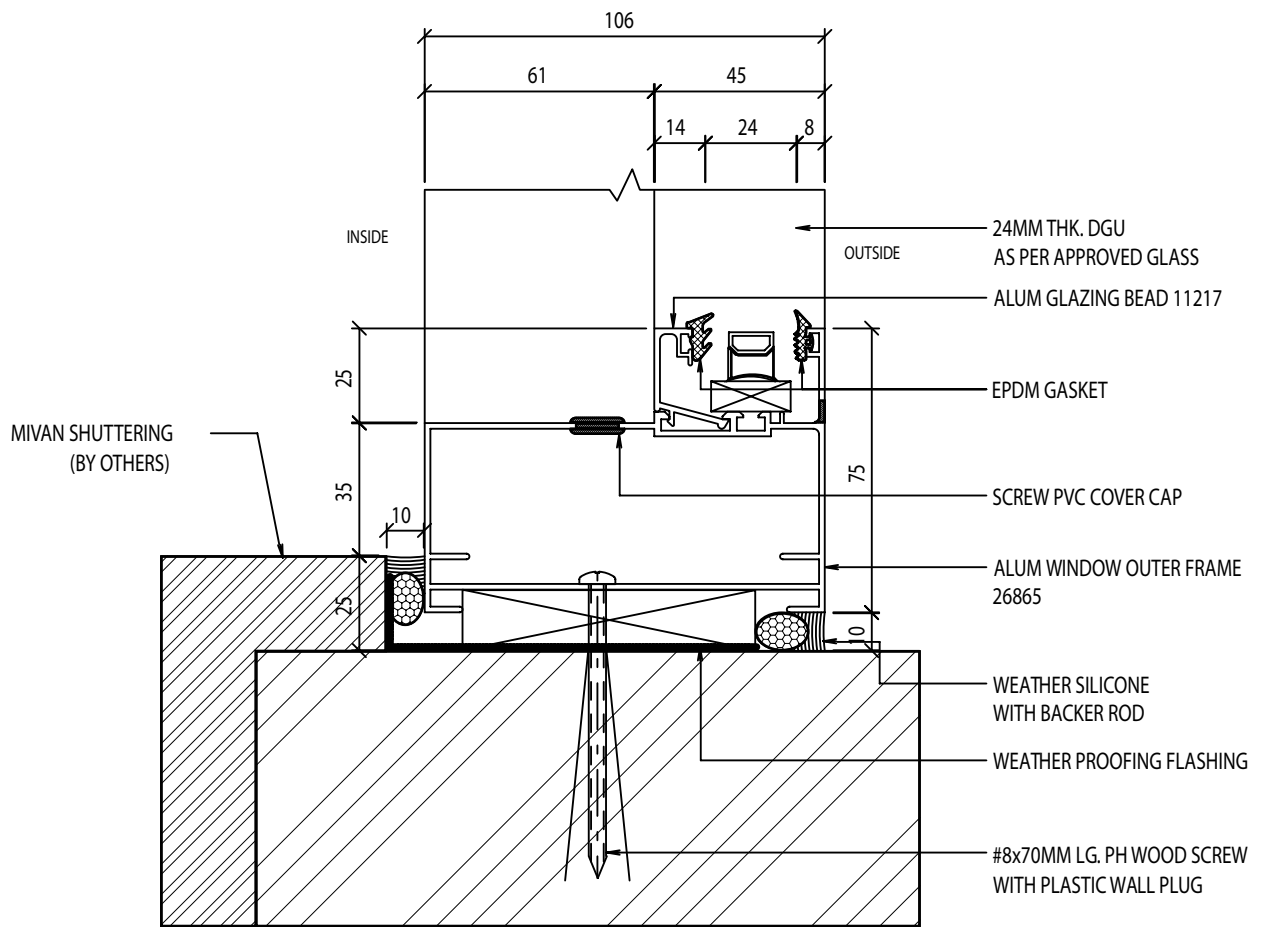

FIX PANEL MULLION DETAIL

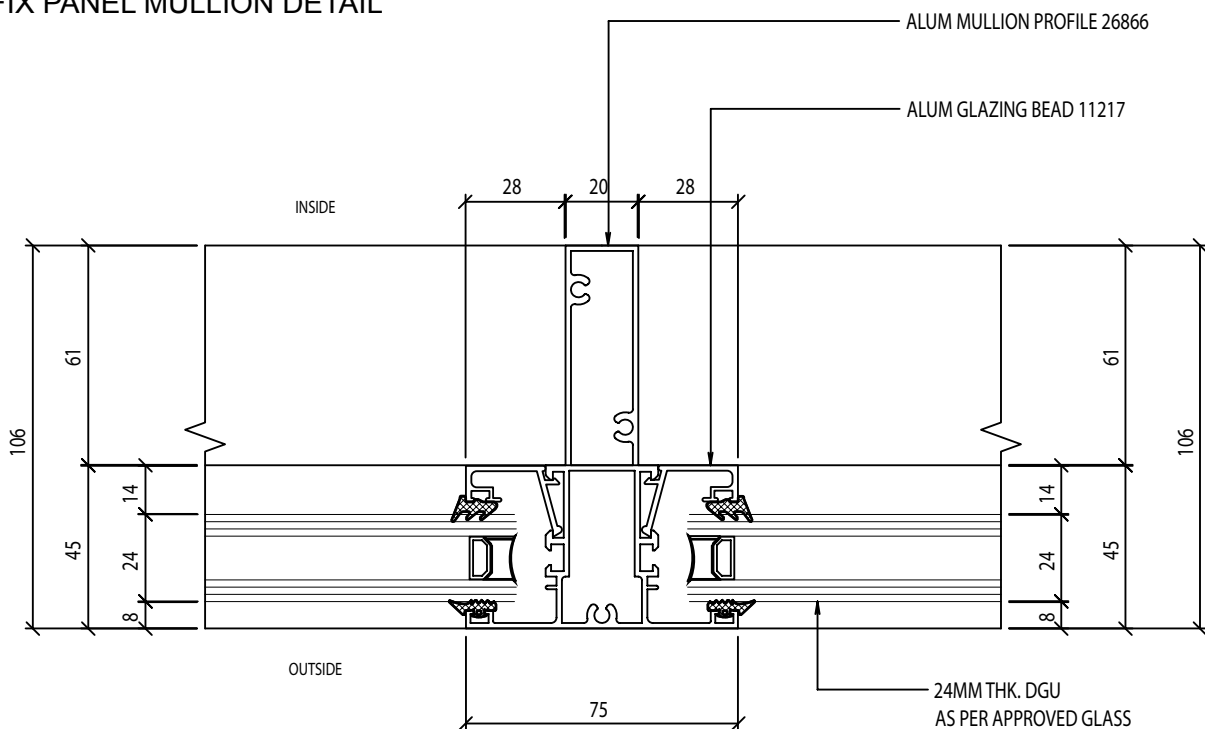

OPENABLE WINDOW JAMB DETAIL

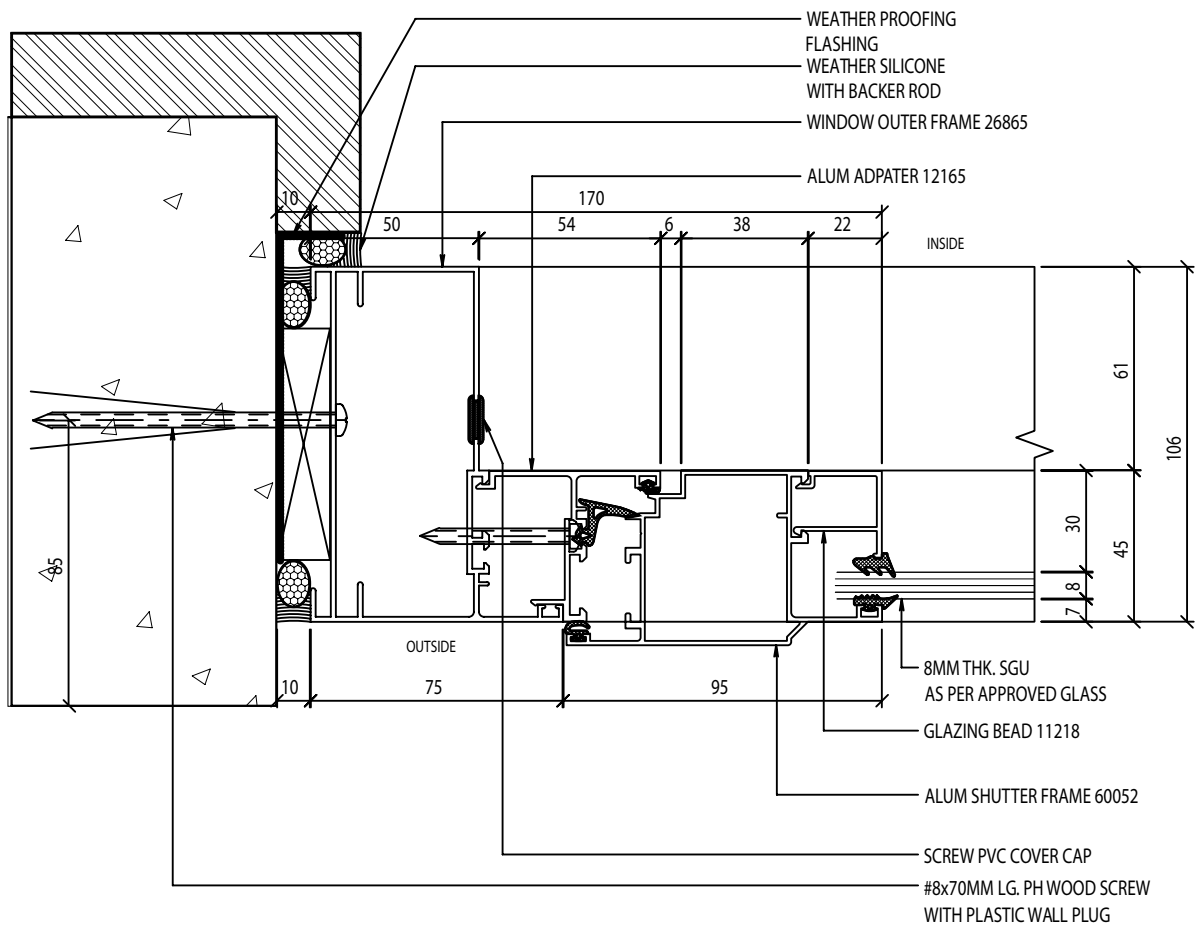

OPENABLE PANEL INTERMEDIATE DETAIL WITH SIDE FIX PANEL

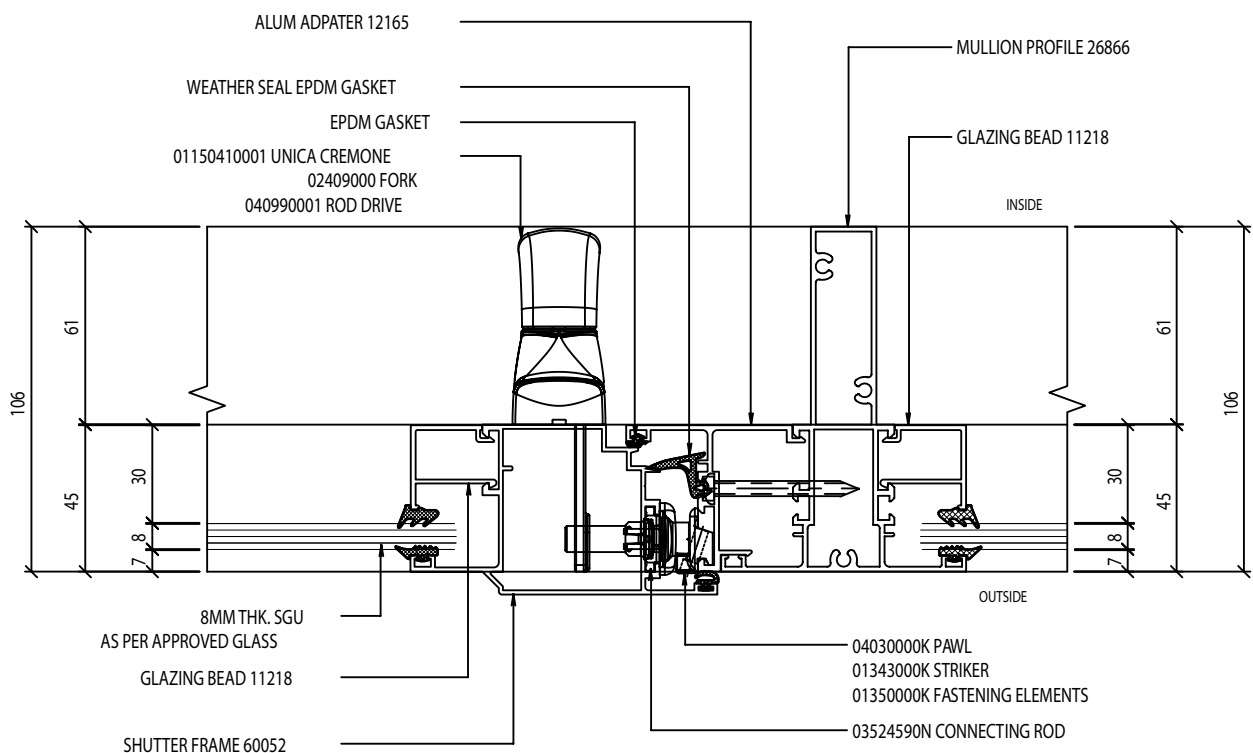



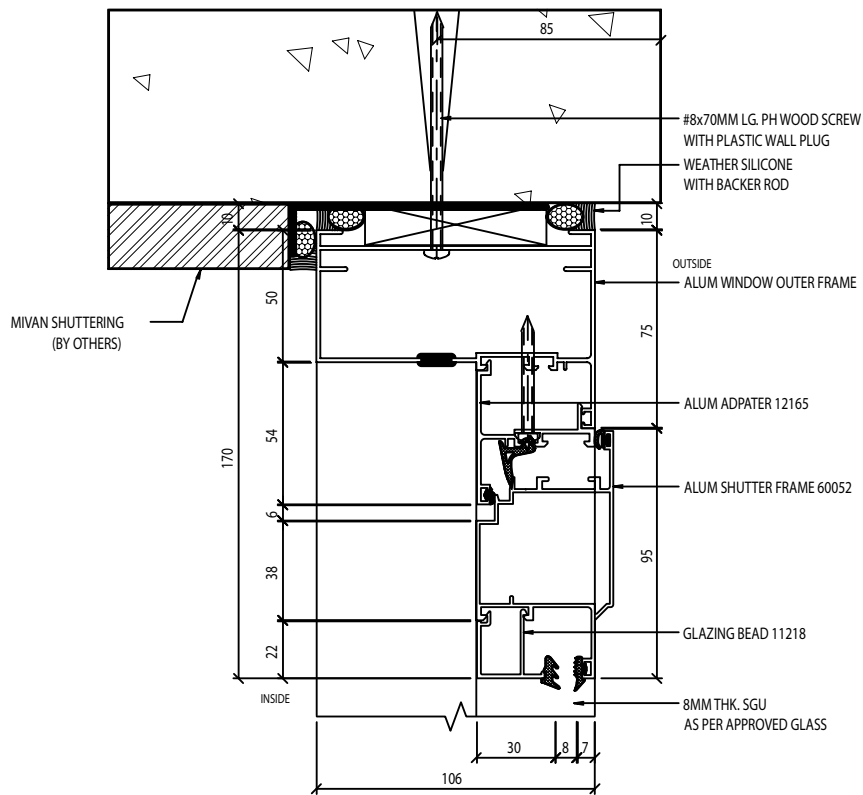

OPENABLE WINDOW JAMB DETAIL

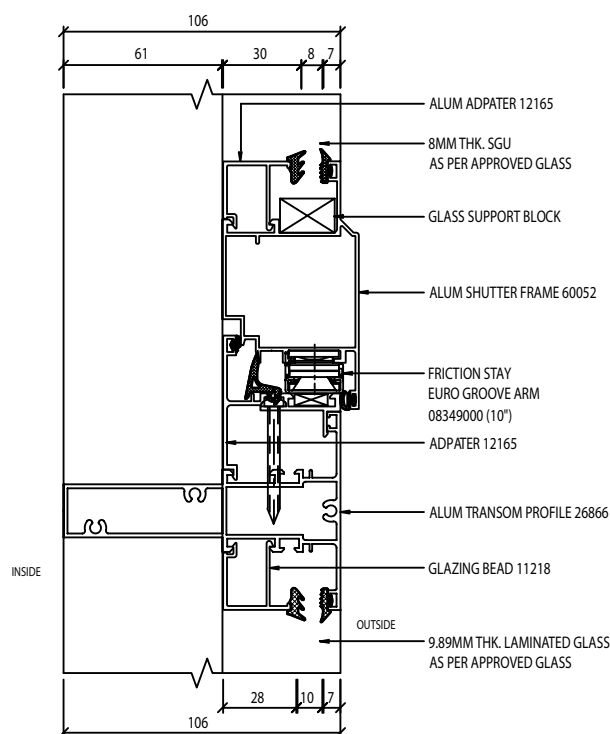

OPENABLE PANEL INTERMEDIATE DETAIL WITH BOTTOM FIX PANEL

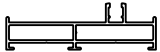

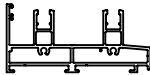
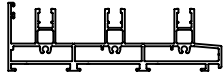
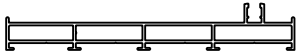
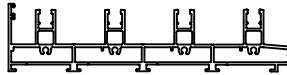
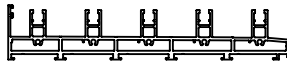
N MINIMAL SERIES

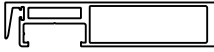
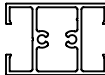
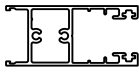
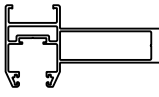

N MINIMAL SERIES				
Profile Reference No:	Profile Section	Weight - Kg/m	IX	IY
26604		1.721	4.05 cm ⁴	74.9 cm ⁴
26602		2.387	5.19 cm ⁴	217.97 cm ⁴
26601		2.460	14.30 cm ⁴	6.09 cm ⁴
26603		3.541	20.32 cm ⁴	295.29 cm ⁴
26598		3.053	63.44 mm ⁴	475.81 mm ⁴
26597		4.622	26.25 cm ⁴	665.07 cm ⁴
27612		7.048	35.56 cm ⁴	1540.12 cm ⁴
26607		1.157	1.87 cm ⁴	1.22 cm ⁴
26606		2.389	6.48 cm ⁴	153.4 cm ⁴
27569		1.137	6.92 cm ⁴	.15 cm ⁴
26600		1.479	10.92 cm ⁴	27 cm ⁴
26605		2.622	19.19 cm ⁴	152.19 cm ⁴

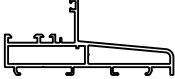
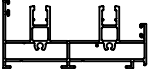
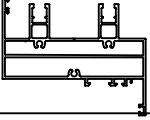
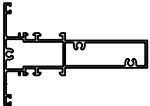
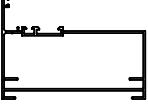
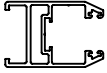
N MINIMAL SERIES

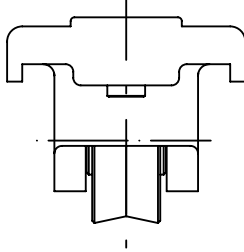
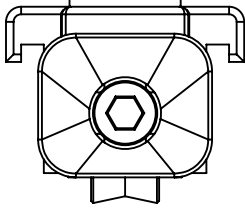
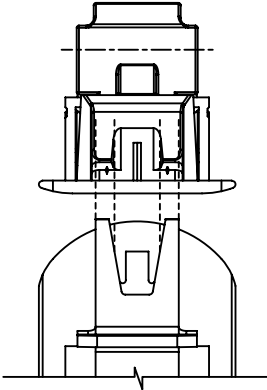
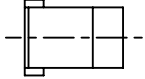
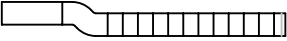
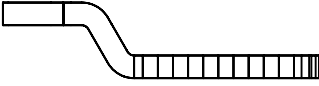

N MINIMAL SERIES				
Profile Reference No:	Profile Section	Weight - KG/M	IX	IY
16073		0.969	1.68 cm ⁴	7.38 cm ⁴
26680		1.692	5.62 cm ⁴	56.76 cm ⁴
26867		2.211	13.25 cm ⁴	91.75 cm ⁴
26868		3.022	33.98 cm ⁴	136.75 cm ⁴
26866		1.740	12.50 cm ⁴	77.41 cm ⁴
26865		1.620	27.71 cm ⁴	93.77 cm ⁴
26599		1.391	14.65 cm ⁴	12.13 cm ⁴

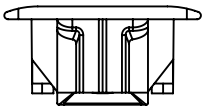
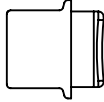
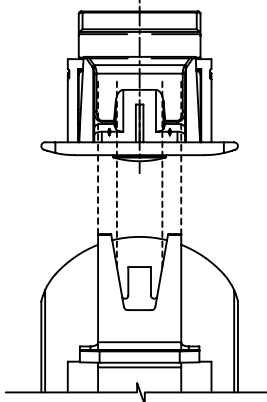
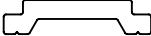
N MINIMAL SERIES

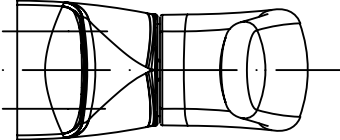
Item Name	Drawing	Item Code
SINGLE PULLEY		03115000
DOUBLE ADJUSTABLE PULLEY		03116000
BRIO L HANDLE		02894
COUNTER PLATE		0332700001
NIB		04582000
NIB		02597000

Item Name	Drawing	Item Code
OUTSIDE HANDLE		02980 BRIO OUTSIDE EMBEDDED HANDLE 02966N BRIO OUTSIDE PULL HANDLE 02967V BRIO KEY OUTSIDE PULL HANDLE 02996 BRIO KEY OUT.PULL HAND.(EURO BARREL)
PAWL		04027000
INSIDE EMBEDDED HANDLE		02983 BRIO PLUS 02883 BRIO PLUS KEY 02992 BRIO 02892 BRIO KEY 02988 BRIO MINI 00831 BRIO RAPID
CONNECTION ROD		03524
28 mm FORK		02403000
UNICA HANDLE UNICA LONG HANDLE		01150 - UNICA HANDLE 01125 - UNICA LONG HANDLE

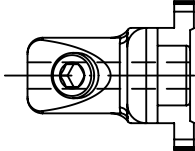
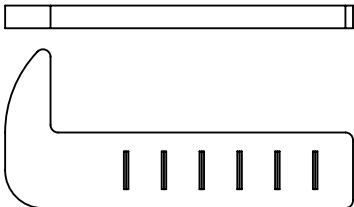
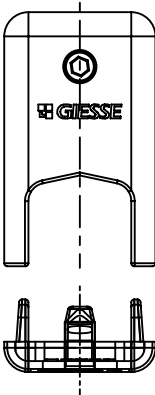
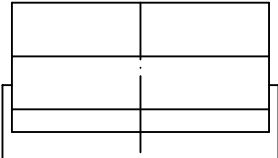
N MINIMAL SERIES

Item Name	Drawing	Item Code
NIB HOLDER		03340000
NIB		03345000
MACHINING COVER PLATE		03485000
DUST-PROOF PLUG		03314000
WEATHER SEAL BRUSH		FS-69-750-HF+1-4P2L OR PB-69-750-4P FS-69-650-HF+1-4P2L OR PB-69-650-4P FS-69-1000-HF+1-4P2L OR PB-69-1000-4P



**NATIONAL ALUMINIUM
PRODUCTS COMPANY SAOG**

OMAN

Corporate Office and Factory
National Aluminum Products Co.
PO Box 15, Rusayl, PC 124, Sultanate of Oman
Phone: +968 24446450, Fax: +968-24446453
Email: sales@napco.co.om, info@napco.co.om

UAE

National Aluminum Products Co. - Branch Office
PO Box 116912, Dubai,
Office 34, Shuraa Business Center
6C Al Abraj St, Business Bay, 29th floor-Prime Tower-Dubai
Phone: +971 045236200

INDIA

NAPCO Extrusions India LLP
4 , Odyssey IT Park,
Road No. 9, Wagle Industrial Estate,
Thane (West) - 400604.
Phone: +91 2220814444

www.napcooman.com